

HygroPro^{II}

Moisture Transmitter User's Manual



HygroPro^{II}

Moisture Transmitter

User's Manual

BH072C11 Rev. C
May 2024

panametrics.com

Copyright 2022 Baker Hughes company.

This material contains one or more registered trademarks of Baker Hughes Company and its subsidiaries in one or more countries. All third-party product and company names are trademarks of their respective holders.

[no content intended for this page]

Chapter 1. Installation

1.1 Introduction1

1.2 Sample System Guidelines 2

1.3 Mounting the Transmitter..... 3

1.4 Wiring the Transmitter 5

 1.4.1 Standard Wiring Connections 5

 1.4.1.1 Standard Connections to Process Controller via Analog Output..... 6

 1.4.1.2 Standard connection with a HART master (handheld device or control system)..... 7

 1.4.1.3 Standard Connections with a PC for field software upgrade..... 8

 1.4.2 Hazardous Area Wiring Connections..... 9

 1.4.2.1 Applicable Standards and Directives 11

 1.4.2.2 Compliance Requirements..... 11

 1.4.2.3 Electrical Connections..... 11

 1.4.2.4 Requirements for External Devices 13

 1.4.2.5 Specific Conditions for Use 13

1.5 HART Communications 13

 1.5.1 HART Connection Point to Point..... 13

 1.5.2 HART Connection Multi-Drop..... 14

1.6 Software Setup 15

1.7 Standard DD File..... 15

Chapter 2. Operation

2.1 Powering Up & Programming17

 2.1.1 Keypad 19

2.2 Basic Setup 19

 2.2.1 Calibration Reminder settings on initial power up..... 19

 2.2.2 Selecting Measurement Parameters 20

 2.2.3 Setting up the Display 22

 2.2.4 Setting up the Analog Output 23

2.3 Advanced Setup..... 25

 2.3.1 Setting Up the Pressure/Temperature Displays 25

 2.3.2 Entering Sensor Calibration Data 26

 2.3.3 Changing the User Passcode..... 27

 2.3.4 Configuring HART Options 28

 2.3.5 About Display/Probe 29

Chapter 3. Service and Maintenance

3.1 The Service Menu..... 31

3.2 Moisture Probe Error Conditions 32

3.3 Cleaning the Moisture Probe 33

 3.3.1 Preparing to Clean the Probe 33

 3.3.2 Replacing the RTE 33

 3.3.3 Removing the Transmitter from the System..... 34

 3.3.4 Removing the Probe from the Transmitter..... 34

 3.3.5 Cleaning the Sensor and the Shield 35

 3.3.6 Installing the Probe in the Transmitter..... 35

 3.3.7 Evaluating the Cleaned Probe..... 36

Chapter 4. Specifications

4.1 General..... 37

4.2 Electrical..... 37

4.3 Mechanical..... 38

4.4 Moisture Sensor 38

4.5 Built-In Temperature Sensor..... 38

4.6 Built-In Pressure Sensor 39

4.7 Certifications 39

Appendix A. HygroPro^{II} HART® Field Device Specification

A.1	Introduction	41
	A.1.1 Scope	41
	A.1.2 Purpose	41
	A.1.3 Who should use this document?	41
	A.1.4 Abbreviations and definitions	41
	A.1.5 References	41
A.2	Device Identification	42
A.3	Product Overview	42
A.4	Product Interfaces	42
	A.4.1 Process Interface	42
	A.4.1.1 Sensor Input Channels	42
	A.4.2 Host interface	42
	A.4.2.1 Analog Output	42
	A.4.2.2 Digital Output	42
	A.4.3 Local Interfaces, Jumpers and Switches	42
	A.4.3.1 Local Controls and Displays	42
	A.4.3.2 Internal Jumpers and Switches	42
A.5	Device Variables	43
A.6	Status Information	44
	A.6.1 Device Status	44
	A.6.2 Extended Device Status	44
	A.6.3 Additional Device Status (Command #48)	44
A.7	Universal Commands	46
A.8	Common-Practice Commands	47
	A.8.1 Supported Commands	47
	A.8.2 Burst Mode	47
	A.8.3 Catch Device Variable	47

A.9	Device-Specific Commands	47
A.9.1	Command 130 (0x82): Set Loop Trim Zero	48
A.9.2	Command 131 (0x83): Set Loop Current Gain	49
A.9.3	Command 132 (0x84): Set Loop Current Percentage	50
A.9.4	Command 133 (0x85): Set Primary Variable Range Values	51
A.9.5	Command 140 (0x8C): Read Primary Variable Range Values	52
A.9.6	Command 144 (0x90): Set Loop Measurement Type	52
A.9.7	Command 146 (0x92): Set Pressure Constant	53
A.9.8	Command 147 (0x93): Read Pressure Constant	54
A.9.9	Command 148 (0x94): Set Temperature Constant	54
A.9.10	Command 149 (0x95): Read Temperature Constant	55
A.9.11	Command 150 (0x96): Set Dew Point Offset	55
A.9.12	Command 151 (0x97): Read Dew Point Offset	56
A.9.13	Command 152 (0x98): Set Number of Hygro Calibration Points	56
A.9.14	Command 153 (0x99): Read Number of Hygro Calibration Points	57
A.9.15	Command 154 (0x9A): Read Hygro Calibration Curve	57
A.9.16	Command 155 (0x9B): Write Hygro Calibration Curve	58
A.9.17	Command 156 (0x9C): Set Pressure Curve	59
A.9.18	Command 157 (0x9D): Read Pressure Curve	59
A.9.19	Command 158 (0x9E): Set Saturation Table Number of Points	60
A.9.20	Command 159 (0x9F): Read Saturation Table Number of Points	60
A.9.21	Command 160 (0xA0): Set Saturation Table Point	61
A.9.22	Command 161 (0xA1): Read Saturation Table Point	62
A.9.23	Command 162 (0xA2): Set Temperature Coefficients	62
A.9.24	Command 163 (0xA3): Read Temperature Coefficients	63
A.9.25	Command 166 (0xA6): Set Saturation Table Index to Read Table Array Element	63
A.9.26	Command 167 (0xA7): Read Saturation Table Index to Read Table Array Element	64
A.9.27	Command 168 (0xA8): Set Hygro Calibration Curve Index to Read Table Array Element	64
A.9.28	Command 169 (0xA9): Read Hygro Calibration Curve Table Index to Read Table Array Element	65
A.9.29	Command 170 (0xAA): Read Loop Measurement Type	65
A.9.30	Command 171 (0xAB): Read Output Trim Zero	66
A.9.31	Command 171 (0xAC): Read Output Trim Span	66
A.9.32	Command 173 (0xAD): Read Loop Current Percentage	67
A.9.33	Command 192 (0xC0): Sends password	68
A.9.34	Command 193 (0xC1): Sends new password	70
A.9.35	Command 194 (0xC2): Read User Level	71
A.9.36	Command 197 (0xC5): Commit the changed parameter	71
A.9.37	Command 198 (0xC6): Cancel the changed parameter	73
A.10	Tables	74
A.10.1	HART Engineering Units	74
A.11	Performance	75
A.11.1	Sampling Rates	75
A.11.2	Power-Up	75
A.11.3	Reset	75
A.11.4	Self-Test	75
A.11.5	Command Response Times	75
A.11.6	Busy and Delayed-Response	75
A.11.7	Long Messages	75
A.11.8	Non-Volatile Memory	75
A.11.9	Modes	75
A.11.10	Write Protection	75
A.11.11	Damping	75
A.12	Capability Checklist	75
A.13	Default Configuration	76
A.14	Revision History	76

Appendix B. HygroPro^{II} Field Service Update User Manual

B.1	Setup	77
	B.1.1 Required Tools	77
	B.1.2 Hardware Setup	77
	B.1.3 Software Setup	78
B.2	Accessing the Bootloader	80
	B.2.1 Activating the Bootloader	80
	B.2.2 Entering the Password	80
	B.2.2.1 To enter the password	80
	B.2.2.2 To enter the password	80
	B.2.2.3 Incorrect Passwords	81
	B.2.2.4 Exiting without inputting a passcode	81
B.3	Using the Bootloader	81
	B.3.1 The Main Menu	81
	B.3.1.1 Accessing the sub menus	81
	B.3.1.2 Exiting the bootloader	81
	B.3.1.3 Menu timeouts	81
	B.3.2 Firmware Details Menu	82
	B.3.2.1 To view firmware details	82
	B.3.2.2 To return to the Main Menu	83
	B.3.3 Download and Install New Firmware Menu	83
	B.3.3.1 Download and install new firmware	83
	B.3.4 Erase NVM Menu	87
	B.3.4.1 To erase non-volatile memory	87

Product Registration

Thank you for purchasing the HygroPro^{II} moisture transmitter from Panametrics. Please register your product at www.bakerhughes.com/productregistration for product support such as the latest software/firmware upgrades, product information and special promotions.

Services



Panametrics provides customers with an experienced staff of customer support personnel ready to respond to technical inquiries, as well as other remote and on-site support needs. To complement our broad portfolio of industry-leading solutions, we offer several types of flexible and scalable support services including: Training, Product Repairs, Service Agreements and more.

Please visit <https://www.bakerhughes.com/panametrics/panametrics-services> for more details.

Typographical Conventions

Note: These paragraphs provide information that provides a deeper understanding of the situation, but is not essential to the proper completion of the instructions.

IMPORTANT: These paragraphs provide information that emphasizes instructions that are essential to proper setup of the equipment. Failure to follow these instructions carefully may cause unreliable performance.



CAUTION! This symbol indicates a risk of potential minor personal injury and/or severe damage to the equipment, unless these instructions are followed carefully.



WARNING! This symbol indicates a risk of potential serious personal injury, unless these instructions are followed carefully.

Safety Issues



WARNING! It is the responsibility of the user to make sure all local, county, state and national codes, regulations, rules and laws related to safety and safe operating conditions are met for each installation.



Attention European Customers! To meet CE Mark requirements for all units intended for use in the EU, all electrical cables must be installed as described in this manual.

Auxiliary Equipment

Local Safety Standards

The user must make sure that he operates all auxiliary equipment in accordance with local codes, standards, regulations, or laws applicable to safety.

Working Area



WARNING! Auxiliary equipment may have both manual and automatic modes of operation. As equipment can move suddenly and without warning, do not enter the work cell of this equipment during automatic operation, and do not enter the work envelope of this equipment during manual operation. If you do, serious injury can result.



WARNING! Make sure that power to the auxiliary equipment is turned OFF and locked out before you perform maintenance procedures on this equipment.

Qualification of Personnel

Make sure that all personnel have manufacturer-approved training applicable to the auxiliary equipment.

Personal Safety Equipment

Make sure that operators and maintenance personnel have all safety equipment applicable to the auxiliary equipment. Examples include safety glasses, protective headgear, safety shoes, etc.

Unauthorized Operation

Make sure that unauthorized personnel cannot gain access to the operation of the equipment.

Environmental Compliance

RoHS

The HygroPro^{II} moisture transmitter fully complies with RoHS regulations (Directive 2011/65/EU).

Waste Electrical and Electronic Equipment (WEEE) Directive

Baker Hughes is an active participant in Europe's *Waste Electrical and Electronic Equipment (WEEE)* take-back initiative (Directive 2012/19/EU).

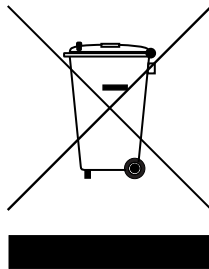

This equipment has required the extraction and use of natural resources for its production. It may contain hazardous substances that could impact health and the environment.

In order to avoid the dissemination of those substances in our environment and to diminish the pressure on the natural resources, we encourage you to use the appropriate take-back systems. Those systems will reuse or recycle most of the materials of your end life equipment in a sound way.

The crossed-out wheeled bin symbol invites you to use those systems.

If you need more information on the collection, reuse and recycling systems, please contact your local or regional waste administration.

Please visit www.bakerhughesds.com/health-safety-and-environment-hse for take-back instructions and more information about this initiative.

[no content intended for this page]

Chapter 1. Installation

1.1 Introduction

The HygroPro^{II} moisture transmitter is a compact, intrinsically safe, loop-powered, 4–20 mA transmitter that provides accurate dew/frost point measurements over a range of –110°C to 20°C (–166°F to 68°F). It features an integrated display and a six-button keypad, and is housed in an IP66/67, NEMA 4X rated enclosure. As shown in Figure 1, the HygroPro^{II} transmitter consists of two major components – the display head with the end user connection and the replaceable transducer element (HygroRTE) or probe assembly that includes all the sensors and read-out electronics.

The HygroPro^{II} transmitter uses a state-of-the-art Aluminum Oxide trace moisture sensor that is temperature compensated for optimal accuracy. It includes a sample temperature sensing thermistor as well as an optional piezo-resistive pressure transducer. All three sensors are mounted on a common hermetically sealed mount isolated from the read-out electronics. In addition to process dew/frost point, it can provide in real time calculated process parameters such as:

- ppm_v in gases
- ppm_w in liquids
- pounds per million standard cubic feet in natural gas
- process relative humidity

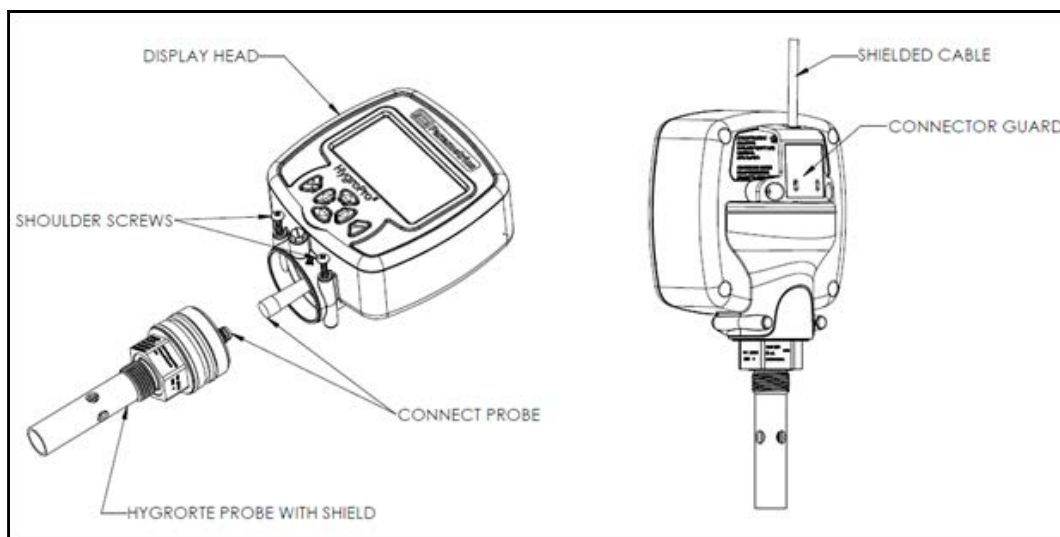

Figure 1: Major components of the HygroPro^{II} – the display head and HygroRTE probe assembly

IMPORTANT: To install the HygroPro^{II} in a hazardous (classified) area, see “Hazardous Area Wiring Connections” on Page 9.

1.2 Sample System Guidelines

The HygroPro^{II} transmitter can be installed in a sample system or directly in the process line. However, Panametrics recommends that the transmitter be installed in a sample system to protect the sensor probe from potentially damaging components in the process stream. Figure 2 below shows a typical sample system.

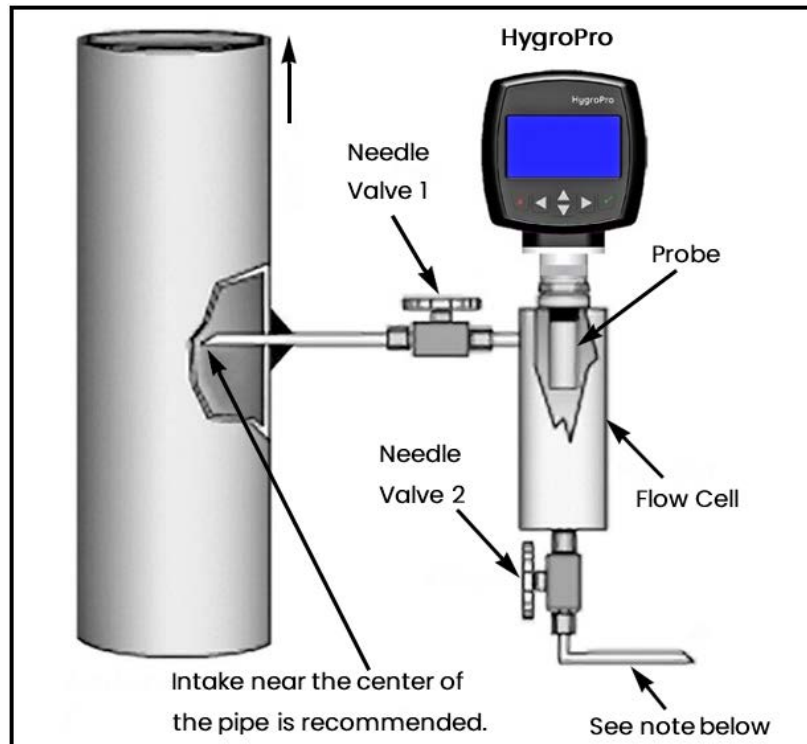

Figure 2: A Typical Sample System

Note: At least 5 ft. (1.5 m) of 1/4" (6 mm) tubing vented to atmosphere will ensure an accurate process sample and avoid diffusion of ambient air moisture back into the process.

In the sample system shown in Figure 2 above, fully open Valve 1 and use Valve 2 to regulate the sample flow for measurements at process system pressure. For measurements at atmospheric pressure, fully open Valve 2 and use Valve 1 to regulate the sample flow.

Before constructing a sample system, consult a Panametrics application engineer and observe the following guidelines:

- The sample system should be very simple and should contain as few components as possible. All or most of those components should be located downstream of the measurement point.
- Sample system components must not affect moisture readings. Most common filters and pressure regulators are not suitable for trace moisture sample systems because the wetted parts adsorb moisture or release moisture into the sample system. They may also allow ambient contamination to enter the sample system. If possible, use stainless steel for all wetted parts.
- The HygroPro^{II} probe should be oriented perpendicular to the sample system inlet. For dimensions and other sample system requirements, see Section 4.3 (Mechanical Specifications) on Page 38.
- Sample systems should be tested for leaks prior to operation, using a Snoop leak detector, to verify the integrity of connections, components and fittings.

IMPORTANT: When pressurizing or depressurizing the sample system, be careful to avoid shock damage to the moisture sensor. Also, the sample pressure should be increased/decreased gradually to avoid explosive decompression of the O-ring.



CAUTION! The O-ring on the HygroRTE probe mount at the base of the 3/4-16 straight thread should be checked prior to mounting the HygroPro^{II} and replaced if necessary. Failure to replace the O-ring when the probe is dismantled and replaced can result in hazardous gas leaks.

1.3 Mounting the Transmitter



CAUTION! If the HygroPro^{II} will be installed directly into the process line, consult Panametrics for proper installation instructions and precautions before proceeding.

Refer to Figure 3 below and complete the steps on the next page to install the HygroPro^{II} transmitter.

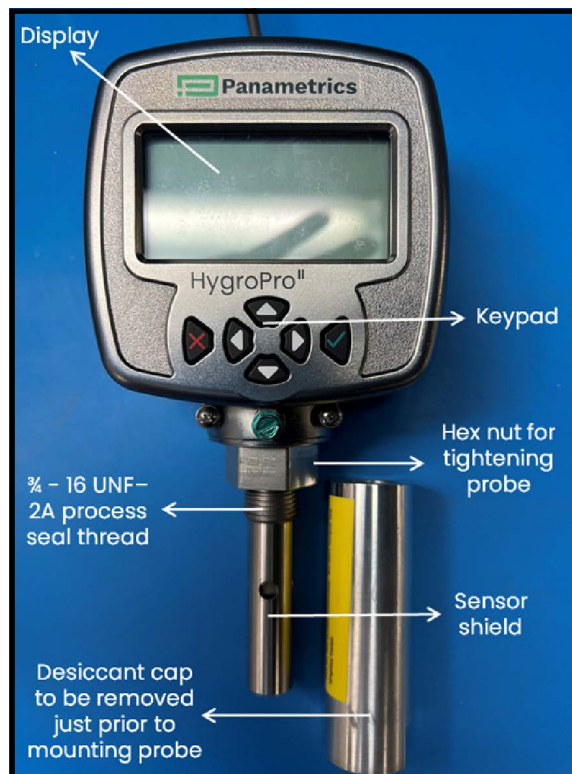

Figure 3: Key HygroPro^{II} parts relevant to installation

1. Make sure the stainless-steel sensor shield is in place over the sensor. This shield protects the aluminum oxide sensor from damage during operation.
2. Using the integral 3/4-16 straight male thread, screw the probe end of the transmitter into the process or sample system fitting. Make sure not to damage the threads.

Note: A 3/4-16 to G 1/2 thread adapter is available from Panametrics.

3. Using a 1-1/8" wrench on the probe hex nut, tighten the probe securely into the process or sample system fitting.



CAUTION! Do not apply torque to the transmitter display module to tighten the unit into its sample system fitting.

Note: Do not unscrew and remove the metal desiccant cap from the probe until just prior to installation of the probe in the process.

Note: If there is insufficient space to rotate the HygroPro^{II} during installation, remove the Replaceable Transducer Element (RTE) from the transmitter, install it in the fitting, then re-install the transmitter display onto the RTE (see Section 3.3).

Note: At least 5 ft. (1.5 m) of 1/4" OD (6 mm) tubing vented to atmosphere will ensure an accurate process sample and avoid diffusion of ambient air moisture back into the process.

Installation of this transmitter on the process can be done in three easy steps as described below:

Step 1: Connect the shielded 4-wire cable supplied with the HygroPro^{II} to the keyed bulkhead connector on the back of the transmitter using the threaded M8 connector. Then install the cable protector on the back with its two captive screws. Care should be taken to thread the connector-free end of the cable through the slot in the cable protector prior to installing it on the HygroPro^{II} so as not to damage the cable.



Figure 4: HygroPro^{II} installation step 1 – initial wiring

Step 2: Just prior to installation on the process, gently unscrew the Aluminum desiccant cap from the bottom of the probe to expose the shielded Aluminum Oxide moisture sensor to the process gas. Discard the desiccant packs enclosed in the cap.

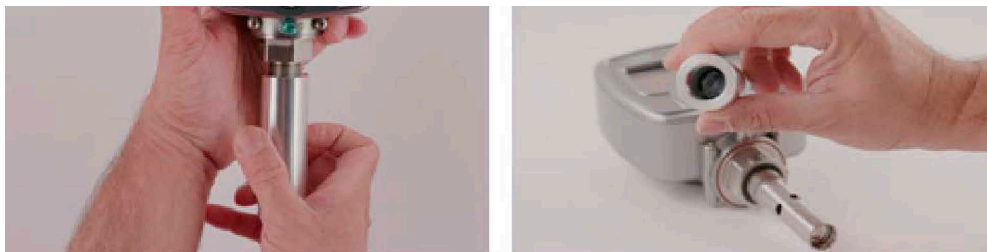

Figure 5: HygroPro^{II} installation step 2 – removing desiccant cap

Step 3: Install the HygroPro^{II} into the process by threading it into the sampling port or sample cell. Please note the transmitter should be tightened using a 1-1/8" wrench only on the hex nut of the probe until it is sealed on the O-ring surface. Please do not torque the display head, but gently swivel it to face the correct direction after the probe is fully tightened.



Figure 6: HygroPro^{II} installation step 3 – installing into sample cell

1.4 Wiring the Transmitter

Proceed to the appropriate section for instructions on:

- Standard Wiring Connections (proceed to the next page)
- Hazardous Area Wiring Connections (proceed page 9)

1.4.1 Standard Wiring Connections

The HygroPro^{II} is a 4–20 mA loop-powered device that can use the same two conductors for its measurement signal lines and its power supply lines. Follow the installation instructions in this section only for units **not** requiring hazardous (classified) area protection.

IMPORTANT: To install the HygroPro^{II} in a hazardous (classified) area, see “Hazardous Area Wiring Connections” on Page 9.

The transmitter must be wired using the factory-supplied 2-meter or 10-meter 4-wire shielded black standard cable. If a different cable length is required, please contact the factory for assistance.

Note: If a longer cable is required, you may splice an extension onto the standard cable. Please be sure to connect leads of the same color together. For example, connect blue lead to blue lead, brown lead to brown lead, etc.

The HygroPro^{II} may be connected to the following types of external data acquisition and control systems:

1. An external device (such as a process controller) that can provide the loop power to the HygroPro^{II} and can also receive and display the 4-20 mA analog output from the HygroPro^{II} (proceed to next page)
2. A Highway Addressable Remote Transducer (HART) communicator (handheld device or plant control system) that can communicate digitally with the HART enabled HygroPro^{II} transmitter over the same two wires as used for the analog output in either a point-to-point or multi-drop configuration)
3. An external power supply to provide power to the HygroPro^{II} plus a personal computer (PC) running TeraTerm or other terminal emulator that can be used for field upgrade of the HygroPro firmware (proceed to page 9)

IMPORTANT: To install the HygroPro^{II} in a hazardous (classified) area, see "Hazardous Area Wiring Connections" on Page 9.

1.4.1.1 Standard Connections to Process Controller via Analog Output

Refer to Figure 7 below and Table 1 below, and complete the following steps to wire the transmitter.

Table 1: Cable leads for Analog Output

Lead	Connection Description
Blue	Power Supply (+) [12-28 VDC]
Brown	Power Supply (-) [Return]
Shield	Earth Ground [recommended]

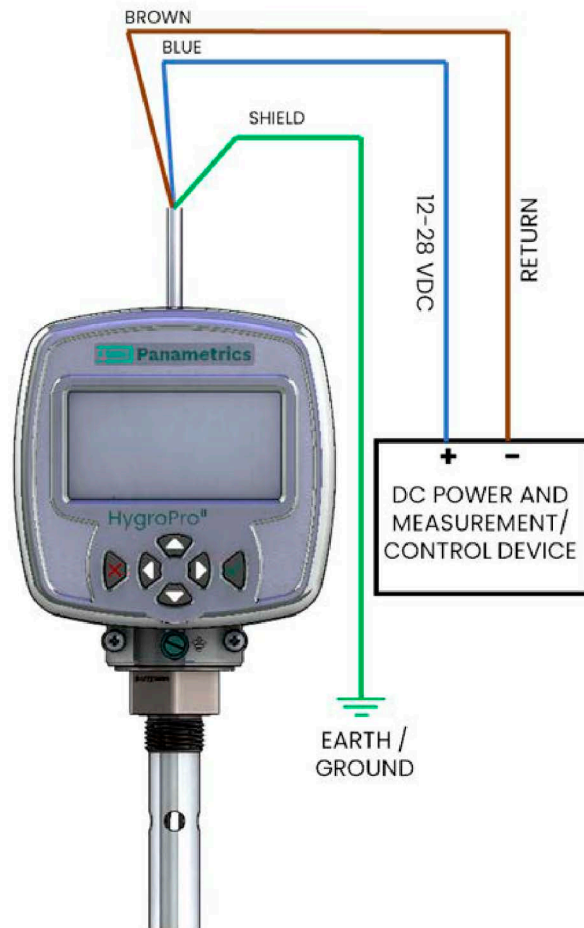

Figure 7: Standard connection to Process Controller via Analog Output

1. Push the keyed female M8 connector end of the factory-supplied standard (black) cable into the mating bulkhead connector on the back of the transmitter module.
2. Make sure the pins are properly aligned using the key in the female connector. Then, secure the connectors together by sliding the metal sleeve on the female connector over the bulkhead connector and turning it clockwise until it is tight.
3. Using the flying leads at the other end of the factory-supplied cable, connect the transmitter to the external analog power and measurement device.

Note: The blue and brown leads also carry the measurement signal current output of 4-20 mA.

4. Trim any unused leads even with the outer cable jacket to remove any bare wire and prevent accidental short circuits.

1.4.1.2 Standard connection with a HART master (handheld device or control system)

1. Push the keyed female M8 connector end of the factory-supplied cable into the mating male connector on the back of the transmitter module.
2. Make sure the pins are properly aligned using the key in the female connected. Then, secure the connectors together by sliding the metal sleeve on the cable over the connectors and turning it clockwise until it is tight.
3. Using the brown and blue flying leads at the other end of the factory-supplied cable, connect the HygroPro^{II} as shown below to the 24 VDC power supply through the 250 Ω load resistor that is used to convert the 4 – 20 mA output to a 1 – 5 VDC signal.
4. Trim any unused leads even with the outer cable jacket to remove any bare wire and prevent accidental short circuits.
5. The HART protocol allows for up to two masters to be connected simultaneously to a single HART slave (HygroPro^{II}).

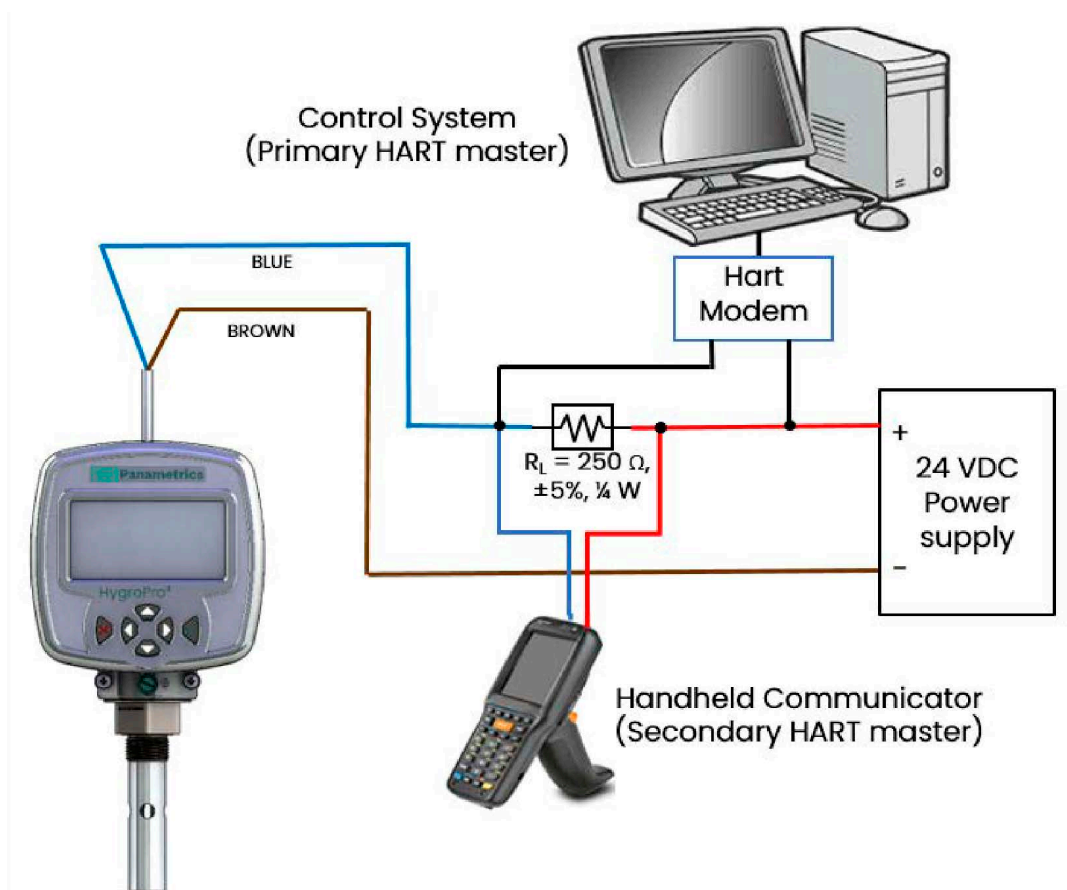

Figure 8: Standard connections with HART master devices (handheld and Plant Control system)

1.4.1.3 Standard Connections with a PC for field software upgrade

Refer to Figure 9 on the next page and Table 2 below, and complete the following steps to wire the transmitter.

Table 2: Cable Leads - With a PC

Lead	Connection Description
Blue	Power Supply (+) [12-28 VDC]
Brown	Power Supply (-) [Return]
White	RS485-RS232 Converter (+) [positive]
Black	RS485-RS232 Converter (-) [negative]
Ground	Earth Ground

1. Connect an RS485-to-USB adapter (customer-supplied) to an available serial port on the PC.
2. Push the female connector end of the factory-supplied cable into the mating male connector on the transmitter module. Make sure the pins are properly aligned. Then, secure the connectors together by sliding the metal sleeve on the cable over the connectors and turning it clockwise until it is tight.
3. Using the flying leads at the other end of the factory-supplied cable, connect the transmitter to the RS-485-to-USB adapter. The cable shield should be connected to the common terminal.
4. Trim any unused leads even with the outer cable jacket to remove any bare wire and prevent accidental short circuits.

IMPORTANT: To install the HygroPro^{II} in a hazardous (classified) area, see "Hazardous Area Wiring Connections" on Page 9.

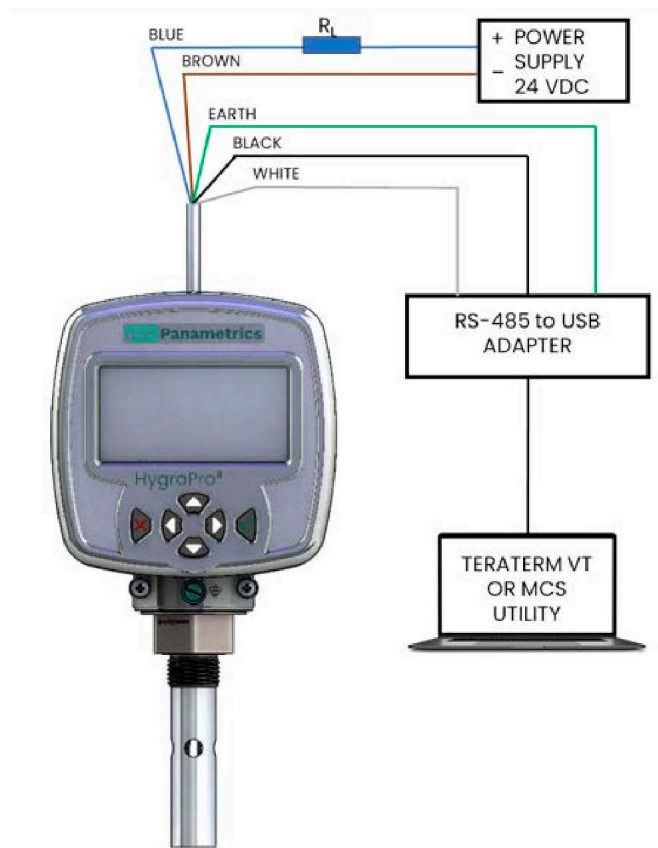

Figure 9: Standard connections with a PC

1.4.2 Hazardous Area Wiring Connections

Before installing and using the HygroPro^{II} in a hazardous (classified) area, be sure to read and understand all applicable reference materials. This includes:

- all EU or North American Standards and Directives (see Table 3 and Table 4 on page 11)
- all local safety procedures and practices
- the FM Schematic drawing (see Figure 10 below)
- this user's manual

Note: It is the installer's responsibility to follow all applicable technical regulations, standards and procedures.



WARNING! The procedures in this section must be performed only by trained technicians who have the necessary skills and qualifications.

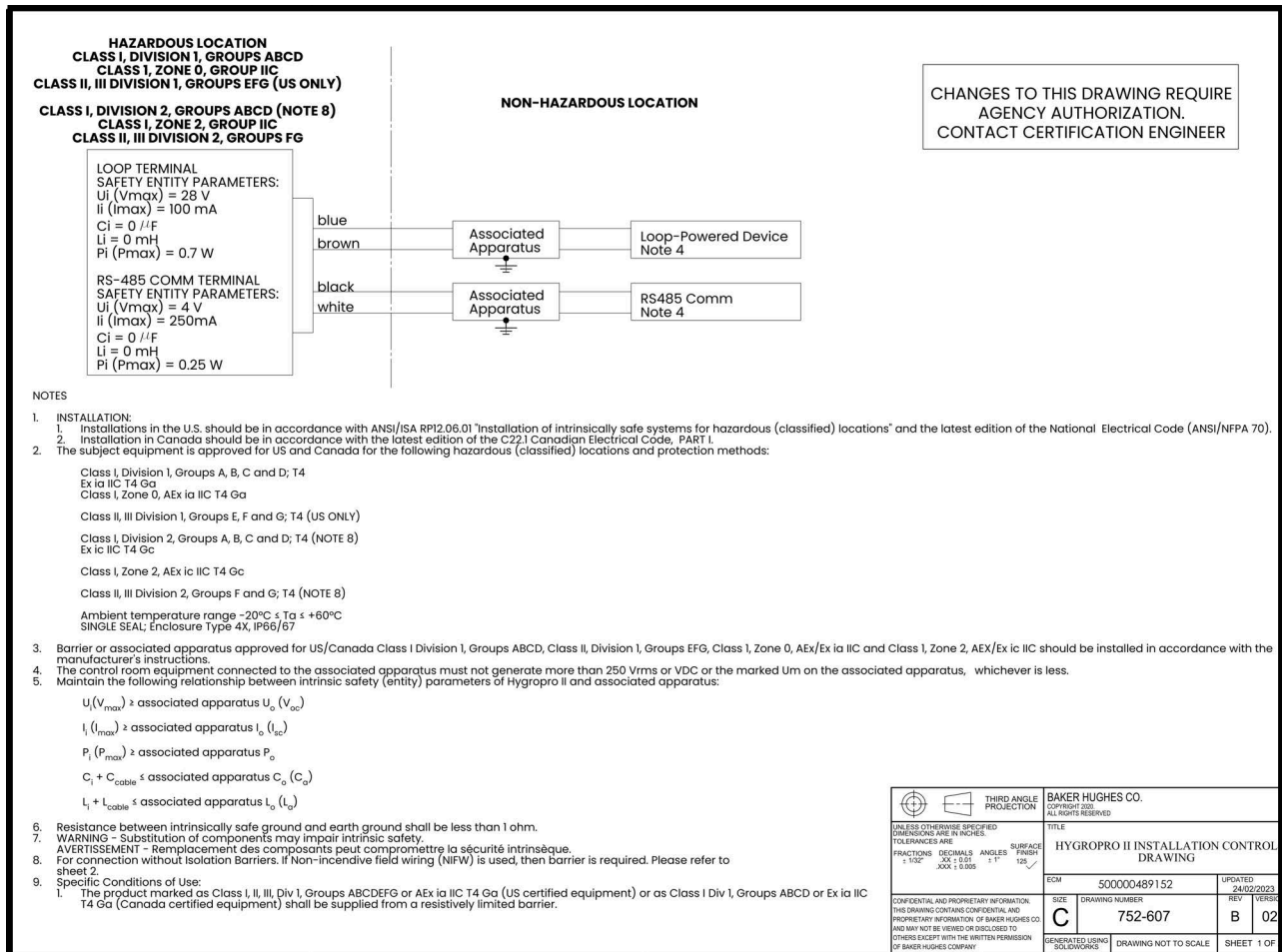

Figure 10: HygroPro^{II} Installation Control Drawing for Division 1 and Division 2 locations (refer to 752-607)

For wiring the HygroPro^{II} in hazardous (classified areas) connect the flying lead end of the IS cable assembly supplied with the transmitter as shown in the installation control diagrams in Figure 10 and Figure 11, according to one of the following conditions:

- **With appropriate rated Zener Barrier/Galvanic Isolator:** Required for use in Class I, Zone 0 and Class I/II/III Division 1 hazardous areas (Figure 10).
- **No Zener Barrier/Galvanic isolator:** For use in Class I/II/III, Division 2 hazardous areas only (no control drawing required).
- **Non-incendive Field Wiring and Zener Barriers:** For use in Class I/II/III, Division 2 hazardous areas only (Figure 11).



WARNING! For IS (Intrinsically Safe) applications in Division 1 or Zone 0 areas, , the HygroPro^{II} must be installed with a Zener barrier (see Figure 9). Also, for installations in a hazardous location, the blue IS cables (P/N 230-094 or 230-057) must be used.

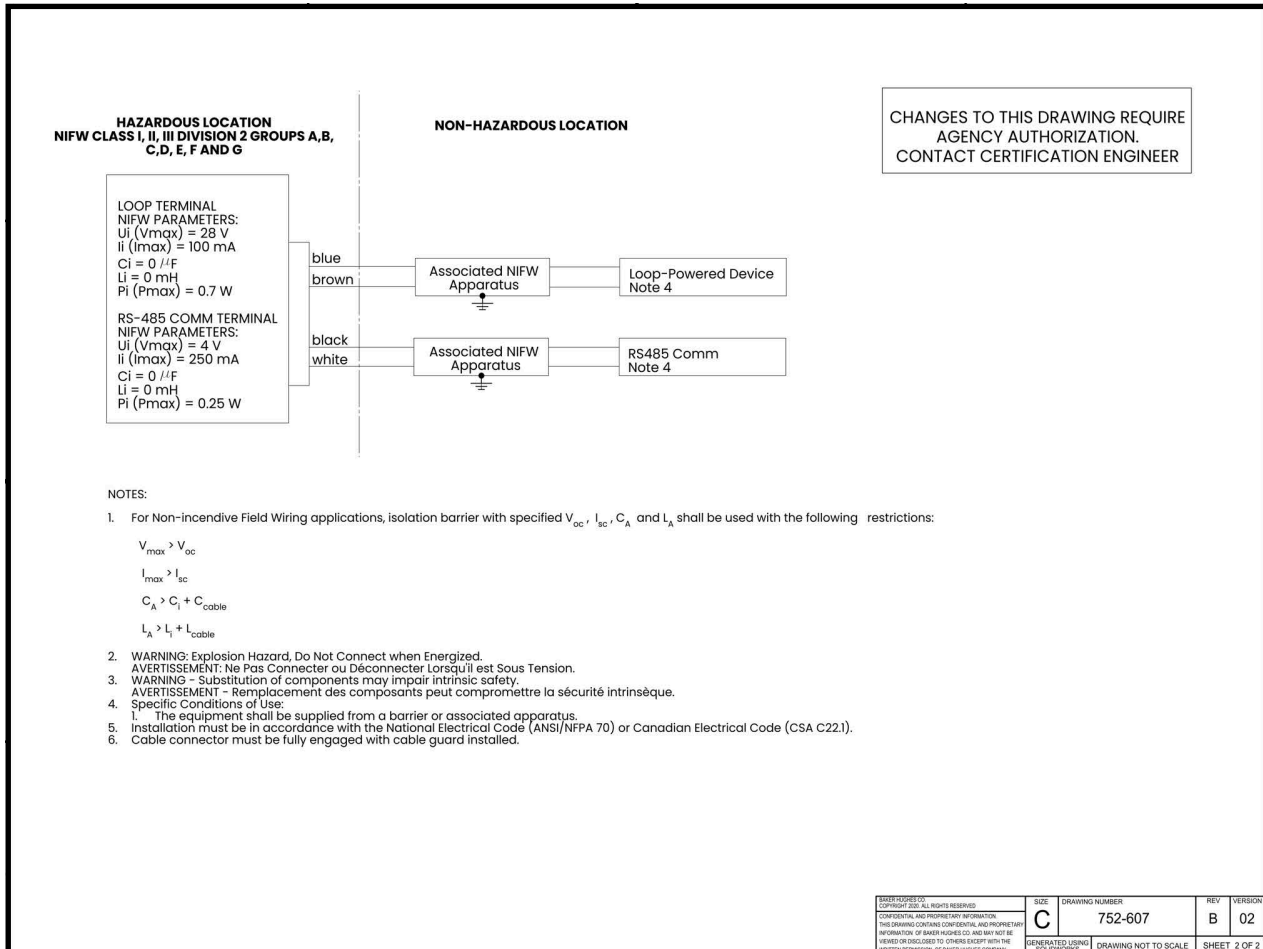

Figure 11: HygroPro^{II} Installation Control Drawing for Non-incendive field wiring in Division 2 locations (refer to 752-607)

1.4.2.1 Applicable Standards and Directives

When the HygroPro^{II} is installed in hazardous areas with potentially explosive atmospheres, it complies with the ATEX 2014/34/EU equipment directive, the EU standards listed in Table 3 below, and the North American FM/CSA and IEC standards listed in Table 4 below.

Table 3: European Union (EU) Standards

Title	Number	Date
Electrical apparatus for explosive gas atmospheres: Part 0: General Requirements Equipment	EN/IEC 60079-0	2018
Explosive atmospheres: Part II: Equipment Protection by intrinsic safety "i"	EN/IEC 60079-11	2012
Degrees of Protection Provided by Enclosures (IP Code)	EN/IEC 60529	2013

Table 4: North American Standards

Title	Number	Date
Electrical Equipment for Use in Hazardous (Classified) Locations General Requirements	Class No. 3600	2021
Intrinsically Safe Apparatus and Associated Apparatus for use in Class I, II, & III, Division 1, and Class I, Zone 0 & 1 Hazardous (Classified) Locations	Class No. 3610	2021
Electrical and Electronic Test, Measuring and Process Control Equipment	Class No. 3810	2021
Non-incendive Electrical Equipment for Use in Class I, Division 2, Hazardous Locations.	CSA-C22.2 No. 213	R2013
Safety requirements for electrical equipment for measurement, control and laboratory use – Part 1: General requirements (Adopted IEC 61010-1:2001, MOD) (Tri-National standard, with UL 61010-1 and ISA 82.02.01)	CSA-C22.2/UL No. 61010-1	2012
Degrees of Protection Provided by Enclosures (IP Code)	ANSI/IEC 60529	2004
Degrees of Protection Provided by Enclosures (IP Code)	CSA-C22.2 No. 60529	R2016

1.4.2.2 Compliance Requirements

The HygroPro^{II} installation must comply with EN 60079-14 standard in Europe and with the National Electrical Code (ANSI/NFPA 70) or part one of the Canadian Electrical Code (C22.1), as applicable, in North America. In other regions, additional local codes may also apply.

1.4.2.3 Electrical Connections

The HygroPro^{II} transmitter is certified intrinsically safe for use in Zone 0. However, the external power must be provided by one of the following methods:

- an isolated, intrinsically safe, 24 VDC power supply mounted in the safe area
- an isolated Zener barrier mounted in the safe area and installed between a standard 24 VDC power supply and the HygroPro^{II}

Refer to Figure 12 on the next page for a typical hazardous (classified) area HygroPro^{II} wiring diagram. This installation uses an MTL706 Zener barrier, in accordance with the second option listed above.

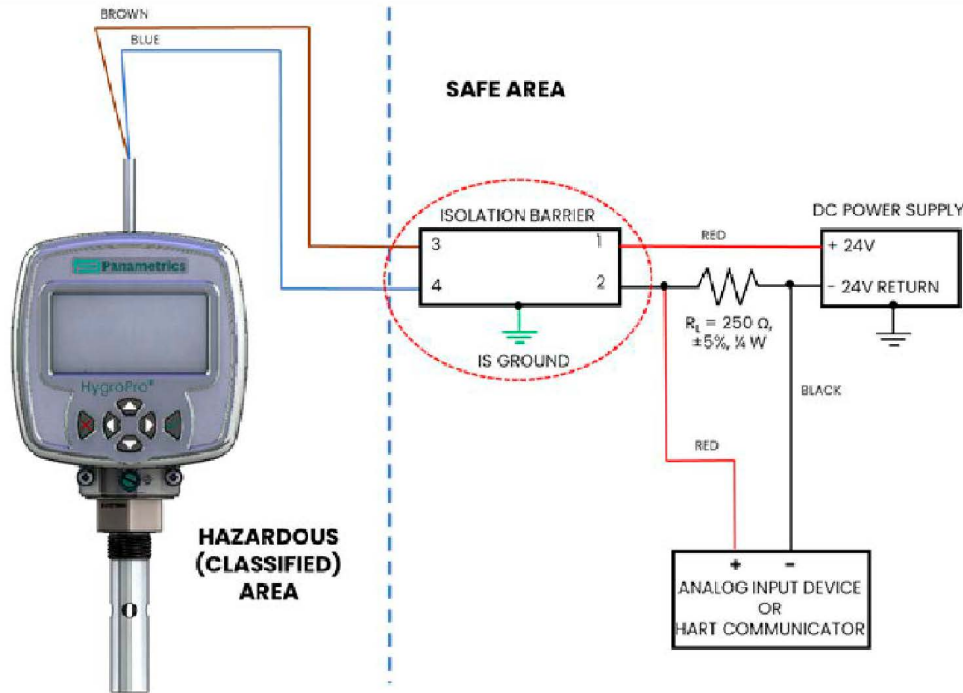

Figure 12: Hazardous Area connections with Analog output or HART device

If using serial communications with a PC, an isolated RS232-RS485 converter mounted in the safe area between the computer and HygroPro^{II} must be used. The converter is typically powered by its own standard 24 VDC power supply.



WARNING! Do NOT power an RS232-RS485 converter from the same intrinsically safe 24 VDC power supply used to power the HygroPro^{II}.

1.4.2.4 Requirements for External Devices

When connecting the HygroPro^{II} to external devices, the allowable total load capacitance and inductance for those devices are listed in the manufacturer's datasheets. The entity parameters of the external devices (e.g. voltage, current and power) must be equal to or lower than the same specifications for the HygroPro^{II}.

The entity parameters for the HygroPro^{II} are listed in Table 5 below.

Table 5: HygroPro^{II} Entity Parameters

Loop Power Supply		
$U_i = 28 \text{ V}$	$P_i = 0.7 \text{ W}$	$L_i = 0 \text{ } \mu\text{H}$
$I_i = 100 \text{ mA}$	$C_i = 0 \text{ } \mu\text{F}$	
RS485 Digital Output		
$U_i = 4.0 \text{ V}$	$P_i = 250 \text{ mW}$	$L_i = 0 \text{ } \mu\text{H}$
$I_i = 250 \text{ mA}$	$C_i = 0 \text{ } \mu\text{F}$	

1.4.2.5 Specific Conditions for Use

The HygroPro^{II} has hazardous area certifications for ATEX (FM22ATEX0011X, FM22ATEX0013X), UKCA (FM22UKEX0011X, FM22UKEX0014X), IECEx (IECEx FMG22.0008X), U.S. (FM22US0016X) and Canada (FM22CA0011X). The "X" at the end of these certificate numbers indicates that special conditions are required for safe operation, which include:

1. The equipment shall be supplied from a resistively limited barrier or associated apparatus.
2. When the manufacturer of the equipment has not identified the type of protection to be used for installation on the label, the user shall, on installation, mark the label with the type of protection used. Once the type of protection has been marked it shall not be changed.



WARNING! Never connect or disconnect the HygroPro^{II} in the hazardous area when supply power or the communication circuit is energized. Isolate the supply lines in the non-hazardous area first.

Following the same special conditions listed above is recommended for regions outside of Europe as well.

1.5 HART Communications

The HART protocol is an open industry standard maintained by the FieldComm Group that makes use of the Frequency Shift Keying (FSK) standard to superimpose digital communication signals at a low level on top of the 4-20 mA analog output. This enables two-way field communication to take place between one or more HART masters and intelligent field transmitters such as the HygroPro^{II}. Superimposing digital signals on the analog output makes it possible for additional diagnostic information beyond just the normal process variable to be communicated with a smart field instrument. The HygroPro^{II} is compatible with HART[®] 7.0 protocol. Hart 7.0 is compatible with earlier versions of the HART protocol. The device supports both Multi-drop and point-to-point communication technology.

1.5.1 HART Connection Point to Point

HART technology is a master/slave protocol, which means that a smart field (slave) device only speaks when spoken to by a master. The HART protocol can be used in various modes such as point-to-point or multi-drop for communicating information to/from smart field instruments and central control or monitoring systems. The HART Protocol provides for up to two masters (primary and secondary) as shown in Figure 5 above. This allows secondary masters, such as handheld communicators to be used, without interfering with communications to/from the primary master, i.e., control/monitoring system.

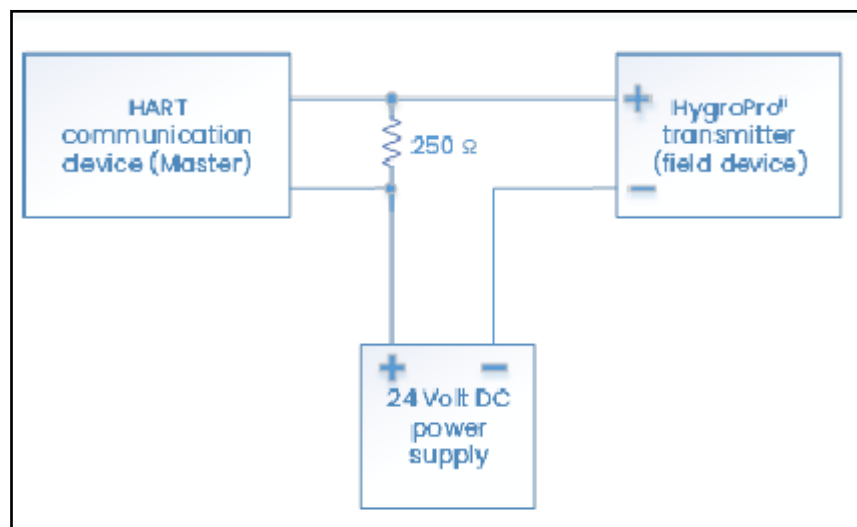

Figure 13: Point-to-point HART connection where up to 2 master devices can be used with HygroPro^{II}

1.5.2 HART Connection Multi-Drop

The multi-drop mode allows for several devices to be connected using the same pair of wires and communicate with the HART master. The HART devices are typically set to addresses other than 0 and the loop current mode is set to disabled. In multi-drop mode the devices will communicate with digital HART communications only. The 4-20mA control signal for the PV is set to a constant value of 4 mA.

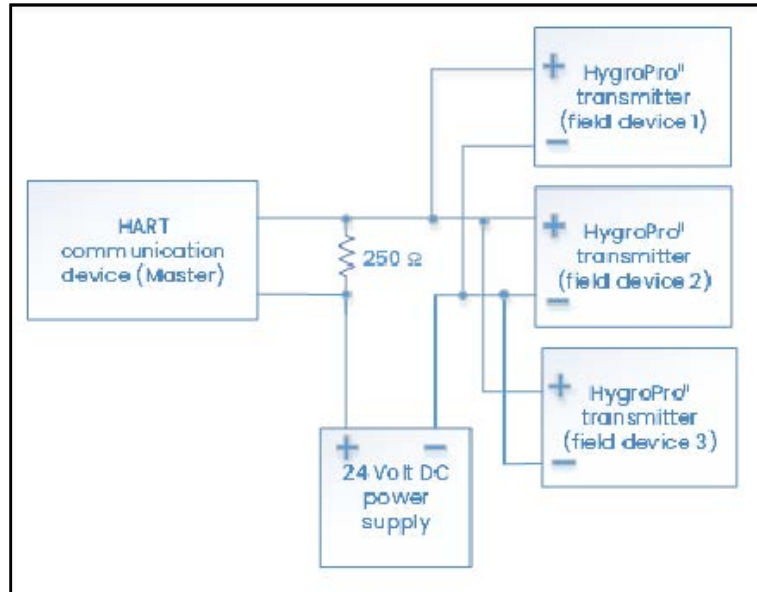

Figure 14: Multi-drop HART connection showing multiple HygroPro^{II} transmitters, each with a unique address, connected to a single HART master

1.6 Software Setup

The HygroPro^{II} is shipped from the factory with HART enabled and configured for point-to-point communication. The HART interface for the device allows for setting up 4 dynamic variables, calibration of the HART DAC and limited programming of the instrument configuration parameters. The device provides three process variables: moisture, temperature, and pressure. Note that some device functions are not available via HART communication.

Three sets of commands – Universal HART commands, Common practice HART commands, and Device specific HART commands – are supported by the HygroPro^{II}. Universal commands are supported by all HART compatible devices. Common practice commands are commands that every field device is expected to support. Device specific commands are specific to the device. For a detailed description of the HygroPro^{II} device specific commands, refer to the HART Field Device specification (FDS) in Appendix A.

Table 6: Valid HART Parameters and Units

Description	Unit	Format	Access Type
Dew point	Dp °C	fp	R
Dew point	Dp °F	fp	R
Dew point	Dp °C Equip	fp	R
ppmw	ppmw	fp	R
Scale low		fp	R/W
Scale high		fp	R/W
Output measurement		fp	R/W
Output Unit		int	R/W
Output mode		int	R/W
Format: fp = IEEE floating point, int = integer, uchar = unsigned character, ucharX = X bytes of unsigned characters. R/W/B:R = read only, W = write only, B = read or write using HART Valid HART Parameters and Units			

1.7 Standard DD File

The Device Description file (rev A) for the HygroPro^{II} field device for HART 7 is available from the FieldComm Group web site www.fieldcommgroup.org. A Device Description ("DD") is a formal description of the data and operating procedures for a field device, including commands, menus and display formats. It describes exactly what you can do to that particular device by HART communication.

It is written as plain text, but is converted into a coded ("tokenised") form for use, for greater efficiency. The DD file contains the standard table view and enhanced view.

The main things the DD describes are Variables, Commands, Methods and Menus. Every accessible variable in the device is included. That means the process measurements, any derived values, and all the internal parameters such as range, sensor type, choice of linearization, materials of construction, etc.

For each Variable, the DD specifies, among other things, the data type (e.g., integer, floating point, alphanumeric, enumerated), how it should be displayed, a name for display to an operator, any associated units, and help text, perhaps describing the meaning of the variable or how it is used.

For each Command, the DD specifies the data structure of the command and its response, and the meaning of any command response status bits.

Methods describe operating procedures, so that a user can be guided through a sequence of actions, for example to re-calibrate the moisture or pressure sensor.

The DD also defines a Menu structure, which a host can use for an operator to find each variable or method.

The standard DD has three top-level menus: Process Variables, Diagram/Service and Detailed Setup. Each of these menus have several sub-menus providing the user with access to the transmitter variables, diagnostics, and some programming capability.

Chapter 2. Operation

2.1 Powering Up & Programming

After the HygroPro^{II} has been installed in a process as described in Chapter 1 (Installation), 12 – 28 V DC power may be applied to the unit. The loop-powered transmitter will show a start-up screen and may require up to 60 seconds for properly initializing, and subsequently commencing normal operation.

The unit will meet its specified Dew Point accuracy within 3 minutes. As noted in the previous Chapter, the AIOx sensor should be kept desiccated and dry down response of the HygroRTE probe depends on the initial moisture level of the AIOx sensor. If the probe has been kept sufficiently dry using the desiccant cap and not exposed to the ambient moisture, it will typically dry down to < 5 PPMv (-65°C Dew Point at 1 atm pressure) in under 15 minutes.

Figure 15 below shows a close-up view of the HygroPro^{II} display and keypad, and Figure 16 on the next page shows a complete menu map of the HygroPro setup program.



Figure 15: HygroPro^{II} Display and Keypad

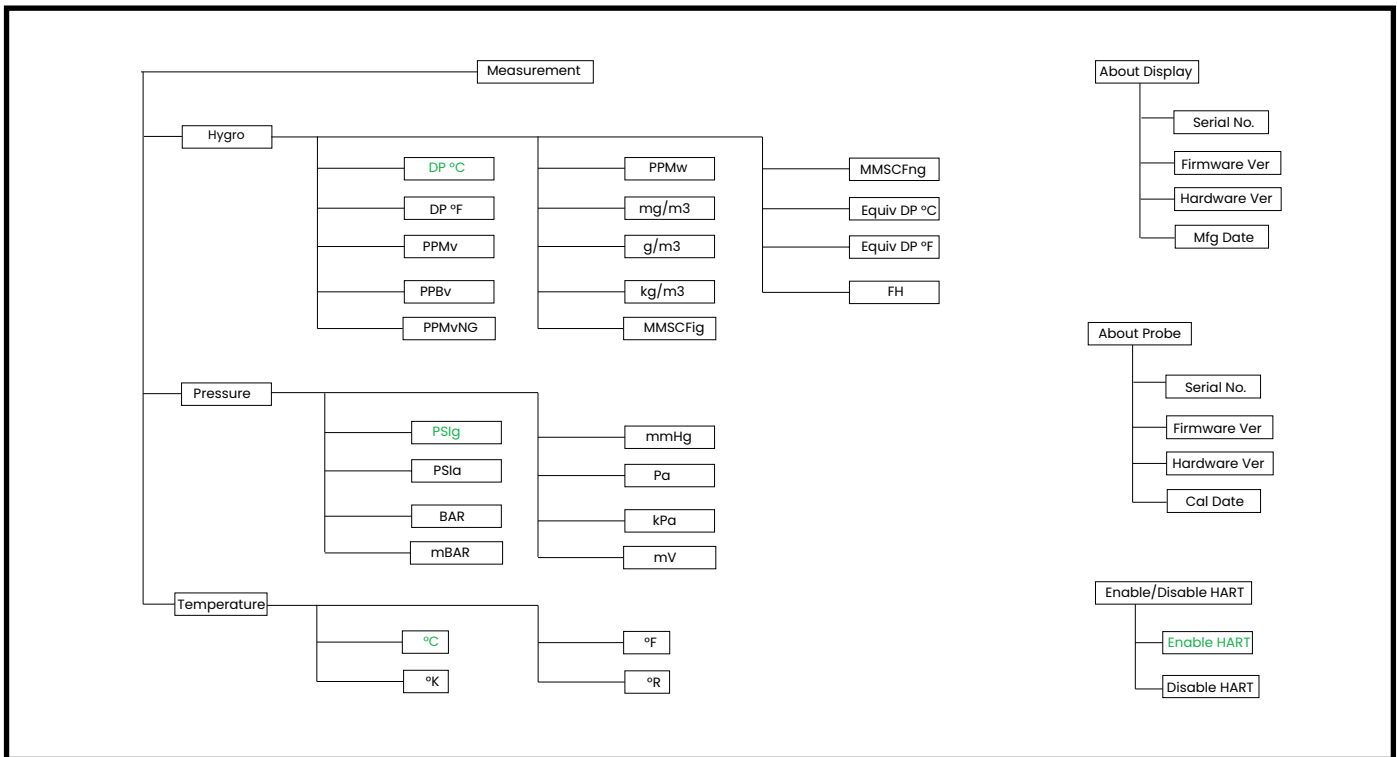
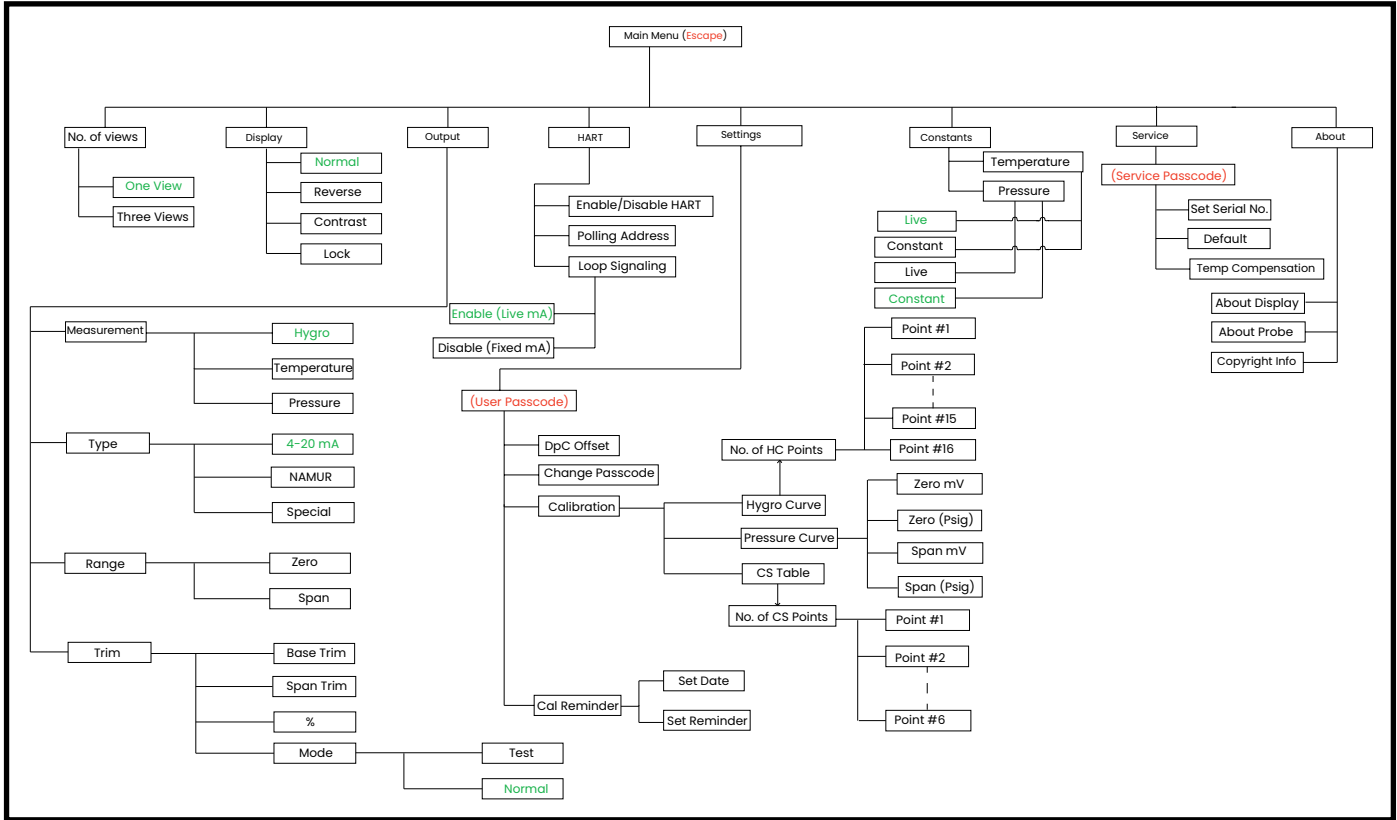

Figure 16: Programming Menu Map

The main menu map shown in two sections above can be accessed by pressing the Escape **X** key. In Figure 16, **red text** indicates special inputs required to access the succeeding section of the menu map, while **green text** indicates the “default” values of the particular menu map branch.

2.1.1 Keypad

After entering the setup program, the keys on the HygroPro^{II} keypad (see Figure 15 on page 17) perform the following functions:

- Enter **✓** – confirm a selection or move to the next screen
- Escape **X** – cancel a selection, move to the previous screen or open main menu
- Up **↑** – scroll upward through a list of options or increase the value of a selected character
- Down **↓** – scroll downward through a list of options or decrease the value of a selected character
- Left **←** – move the cursor to the next character/field to the left
- Right **→** – move the cursor to the next character/field to the right

2.2 Basic Setup

The HygroPro^{II} transmitter is easily programmed to meet the user’s requirements by referring to the menu map in Figure 16 on the previous page and following the instructions in this section. As noted in the figure, the following six top-level parameters can be accessed and set on the HMI without any passcode-

- a) No. of Views
- b) Display
- c) Output
- d) HART
- e) Constants
- f) About

The *Settings* menu requires a 6-digit User passcode (default value 111111) while the Service menu (see Chapter 3) requires a device-specific 6-digit Service passcode (contact Panametrics Tech Support) for access.

2.2.1 Calibration Reminder settings on initial power up

One of the new features offered by the HygroPro^{II} transmitter is automated calibration reminders to the end user. This feature uses an internal clock to determine elapsed time from the HygroRTE probe calibration date.

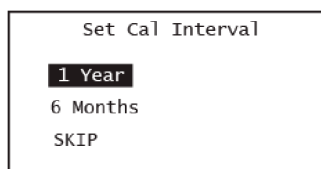
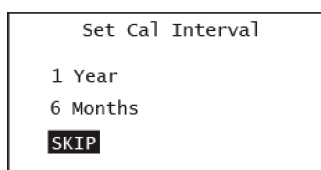

The initial power up screen on the HygroPro^{II} is shown on the left. After going through the boot up splash screen, the device displays the following three choices for the calibration interval:

- 1 Year
- 6 Months
- Skip

The Calibration Interval is defined in months from the probe calibration date after it has been read from the probe non-volatile memory upon initial power up. The end user is expected to set this calibration interval depending of their facility’s policy to one of the above settings.



CAUTION! Panametrics strongly recommends that the HygroRTE probe be sent back to the Billerica, USA or Shannon, IE facilities for recalibration every 6–12 months to ensure accuracy and reliability of the moisture readings.

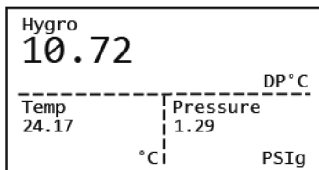
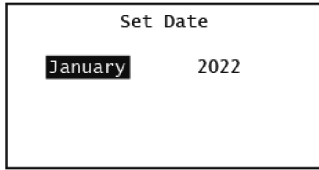

Since the HygroPro^{II} does not use a real-time clock battery, the clock needs to be set upon power up. If the user chooses either 6 months or 1 year, they are then required to enter the current time and date to ensure accuracy of the calibration reminder.

When the calibration reminder feature is enabled (i.e., User does not choose SKIP), the User is required to enter only the month and the year of the current date by selecting either field, and using the Up or Down arrows to change it. Pressing the Enter key saves the current date and time.

If the date and time are saved to the device non-volatile memory correctly, depending on the calibration date of the HygroPro^{II} probe attached, the **ICR** calibration reminder warning will not appear on the display as shown.

If it does appear for a new HygroPro^{II} installation, please contact Panametrics Technical support to check the calibration date of the probe (Serial number engraved on probe mount).

As shown below the **ICR** symbol flashing on the display in the specific spot on the top line indicates the probe is due for recalibration. Note this reminder occurs on the same location on the display regardless of its format (i.e., single view or triple view).

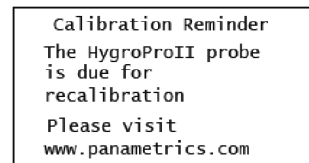
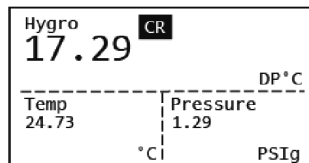
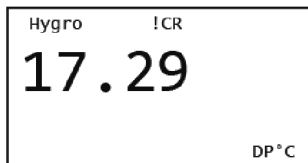

If the user selects the **ICR** reminder by navigating to it on the display using the Up arrow and pressing Enter, then the description of the calibration reminder is displayed along with the Panametrics web page URL.

2.2.2 Selecting Measurement Parameters

To select the measurement parameters, complete the following steps:

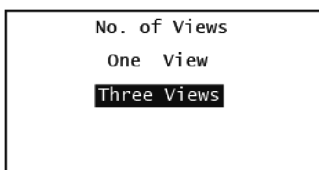
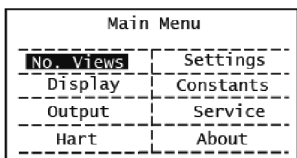

To enter the main menu press **Escape X**.

To select the number of measurements to be displayed on each screen, select # of Views and press **Enter ✓**.

Use the up and down keys to select the number of views desired and press **Enter ✓**.

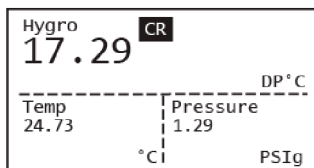

Each selection is confirmed by “Saving to Memory” prompt flashing on the screen after pressing **Enter** ✓.

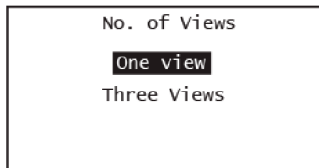

Typical examples of the single and triple measurement views for a given set of measurement choices are shown on the left. The typical format shows the type of measurement in the top left, the measured value in the middle and the units chosen on the bottom right.

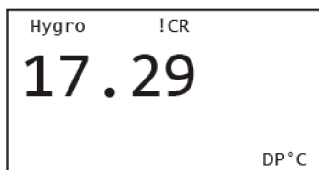

Press Escape to access the Main menu (Figure 16) and access the No. of Views setup to change the view.

To change a measurement parameter, use the arrow keys to highlight the parameter name and then press Enter. Use the up and down arrow keys to select a measurement parameter and then press Enter.

Note: As an example, shown below are the steps for setting up a typical 3-view display where Dew Point, sample temperature and sample pressure have been selected as the measurement parameters to be changed.

Use the arrow keys to highlight Hygro and press Enter to set up this measurement. The next screen shows the three measurements available with Hygro highlighted. Press Enter to display all possible hygrometry measurements available, then use the up and down arrows to navigate to the particular measurement you would like to choose. Press Enter. Again, any change in this selection is confirmed by a “Save Successful” prompt flashing on the screen after pressing Enter.

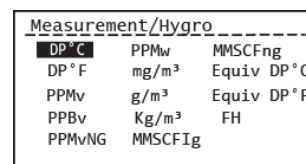
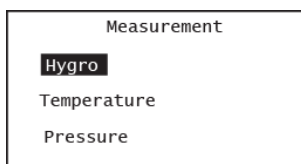
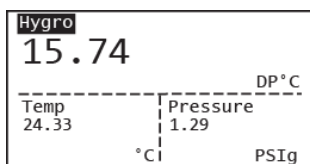

Use the arrow keys to highlight Temp and press Enter to set up this measurement. The next screen shows the three measurements available with Temperature highlighted. Press Enter to display all possible temperature measurements available, then use the up and down arrows to navigate to the particular measurement you would like to choose. Press Enter to return to the main display screen.

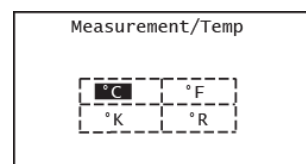
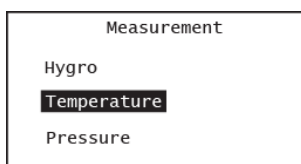
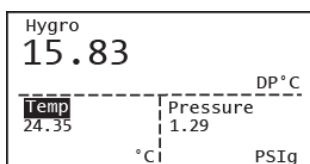

Use the arrow keys to highlight Pressure and press Enter to set up this measurement. The next screen shows the three measurements available with Pressure highlighted. Press Enter to display all available pressure measurements, then use the up and down arrows to navigate to the particular pressure measurement you would like to choose. Press Enter to return to the main display screen.

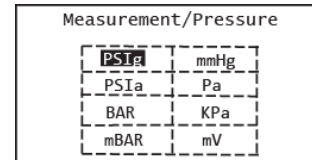
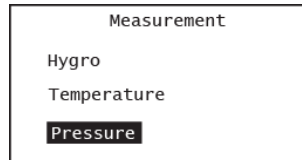
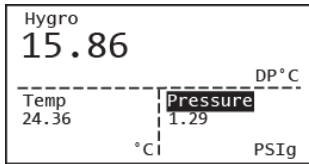

The programming sequence is now complete and you are returned to the View menu. Please note each measurement in HygroPro^{II} has a pre-determined range and resolution, and the number of digits after the decimal point is fixed.

2.2.3 Setting up the Display

To set up the display, complete the following steps:

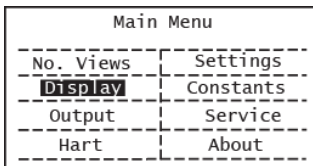

Press Escape to access the main menu, use the up and down keys to select Display and press enter.

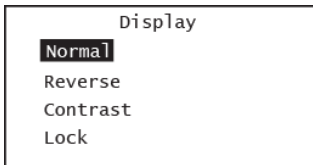

You will see 4 choices under the Display menu as shown on the left.

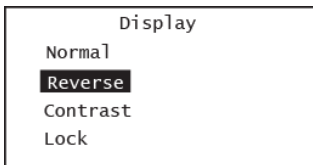

If the Normal display type is acceptable, press Escape to return to the previous menu.

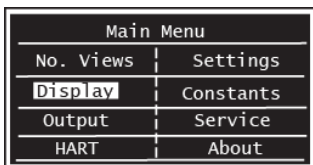

To change the display type, use the up and down keys to select Normal or Reverse and press enter. The reverse display mode is shown on the left.

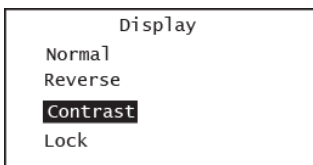

If you wish to change the display Contrast, at the above screen, highlight that choice and press enter.

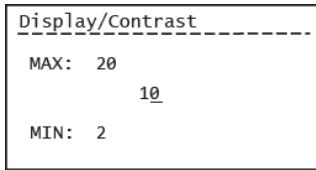

Use the arrow keys to change the Contrast value and press Enter. The default value is set to 10. Then press Enter to return to the main menu.

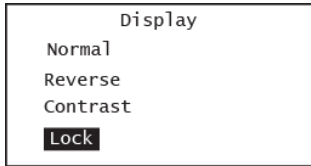

To lock the display press Lock. The display then shows up with lock sign in the top right corner as shown. Please note the default mode for the display is unlocked.

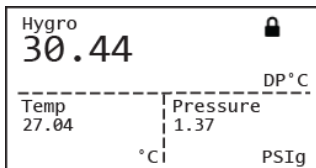

To unlock the display press Enter ✓ Escape ✗, Enter ✓ in that sequence. The Lock sign will disappear from the display.

2.2.4 Setting up the Analog Output

To set up the analog output, complete the following steps (no Passcode required):

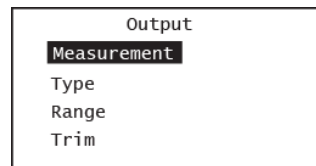
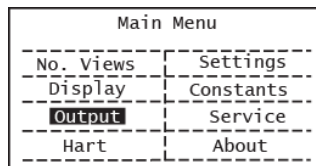

After pressing Escape to access the Main Menu, use the right arrow key to scroll to Output and press Enter.

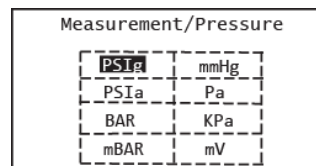
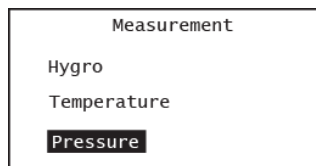

Select the Measurement option and press Enter. Use the arrow keys to scroll to the desired output parameter and press Enter.

In this example, the Pressure measurement is selected. Press Enter to see choice of units available.

Press Enter and the display goes back to the previous screen after briefly showing "Saved to Memory" if any setting is changed.

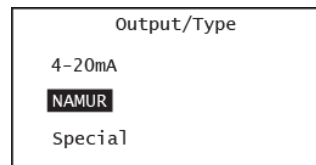
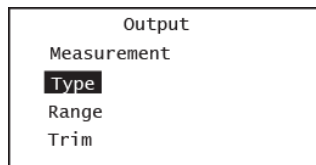

In the Output menu, select Type and press Enter. The screen on the left appears (with 4–20 mA as the default choice):

Select the desired output Type and press Enter. If NAMUR is selected instead, the display goes back to the previous screen on pressing Enter.

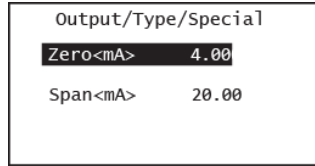
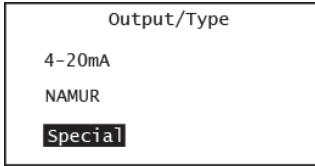

If Special is chosen at the previous prompt, the screen shown on the left appears.

Select Zero and press Enter. Use the arrow keys to enter the zero value for the special output and press Enter.

Repeat the above two steps to enter the Span value for the special output.

In the Output menu, select Range and press Enter. The screen shown on the left appears.

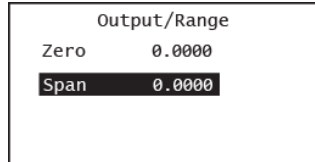
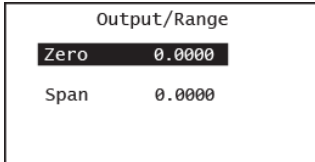

Enter the Zero and Span values for the range, using the same procedure as above.

In the Output menu, select Trim and press Enter. The screen shown on the left appears.

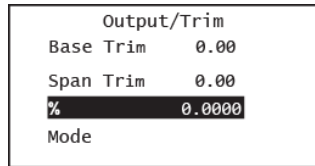
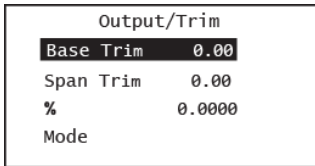

Enter your values for the Base Trim, Span Trim and %, using the same procedures as on the previous screen.

When you select the Mode option at the above prompt, choose either Test to verify the output or Normal for normal operation.

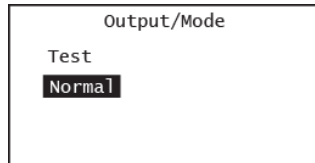
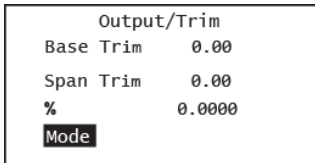

In the Test mode, you can check (and trim if necessary) the output values at any desired % level between 0 and 100%.

2.3 Advanced Setup

The following sections describe the procedures for completing the configuration of your HygroPro transmitter.

2.3.1 Setting Up the Pressure/Temperature Displays

The following steps set the displayed pressure and temperature values to Live (changing with the current measurements) or Constant (remaining the same, regardless of the current measurements). If the Constant option is selected, the desired numerical value must be set. Please note there is no indication on the display if either value is set to Live or Constant.

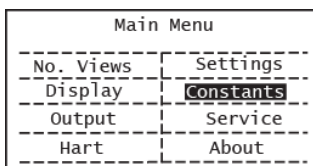

In the Main menu (press Escape) navigate to Constants and press Enter.

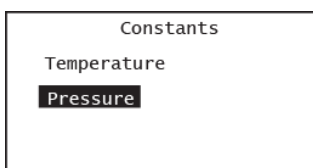

To set the pressure/temperature display, use the arrow keys to select Pressure/Temperature. Press Enter.

Use the arrow keys to select either Live or Constant Pressure or Temperature and press Enter. For example, constant pressure of 70 bar could be selected if the desired measurement output is the Equivalent DP @ 70 bar.



CAUTION!

Please be careful to select sample pressure and temperature settings to the best option for the chosen hygrometry measurement. Certain absolute measurements like mg/m^3 , g/m^3 and PPMv do not depend on sample temperature and/or pressure, while others such as Dew Point, Equivalent DP, and lbs/MMSCF require an accurate live sample pressure and temperature reading.

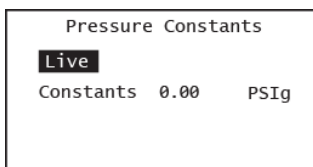

If you selected Constant Pressure, please note the default units, which can be changed by navigating to the Measurements menu as described above.

Use the arrow keys to enter the desired pressure value and press Enter. The screen will be updated to show the new pressure value.

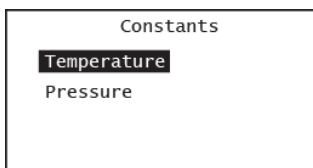

Note: As shown in the Menu map in Figure 16, the default value for Pressure is Constant (0.00 PSIG) as the pressure sensor is optional.

Note: The default value for Temperature is Live as all HygroRTE probes include a temperature sensor.

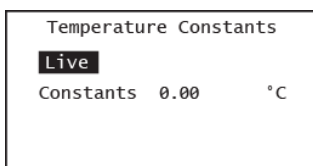

Use the same procedure to set the temperature mode, and if Constant Temperature is selected, to enter the constant temperature value.

2.3.2 Entering Sensor Calibration Data

Main Menu	
No. Views	Settings
Display	Constants
Output	Service
Hart	About

Calibration data for the AIOx moisture sensor and the optional pressure sensor are located under the Settings option on the Main Menu.

Enter the Passcode

000000

These settings are protected by the User Passcode – the default value is **11111** and can be changed as shown below.

Settings	
DPC Offset	Calibration
Cal Reminder	
Change Passcode	

Enter your User password and press Enter. Use the arrow keys to scroll to Calibration. Press Enter. Select Hygro Curve and press Enter.

Calibration	
Hygro Curve	
Pressure Curve	
CS Table	

This will bring you to the No. of HC points screen. Default number of calibration points is 14 (standard HygroRTE calibration), maximum number is 18 (extended calibration). The HC table that appears on pressing Enter will display as many points from point 1 as you select.

No. of HC Points

MAX: 18

14

MIN: 2

Select point 1 (or any point you wish to edit) and press Enter. It is advisable to start at the top and check every single calibration point in order to ensure the probe calibration curve has been entered properly.

Hygro Curve			
1	5	9	13
2	6	10	14
3	7	11	
4	8	12	

The next screen shows the FH (independent variable) and Dew Point (dependent variable) values for that calibration point.

Hygro Curve/Pt. 1

FH 8.7200

Dew Pt C -110

As shown on the left, the first calibration point typically has a DP setting of -110°C while the last (14th) point has a DP setting of +20°C. Use the arrow keys to choose either value, enter a desired value and press Enter.

Hygro Curve/Pt. 14

FH 186.3500

Dew Pt C 20

Repeat the previous two steps until all of your Hygro Curve data points (14 typical, 18 extended) have been entered.

To save the data you have to press Enter. If any numerical value has changed an intermediate screen showing "Save Successful" appears.

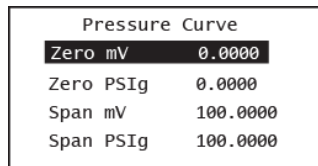
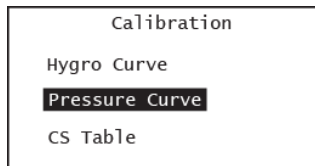

If nothing has been changed you will go back to the Hygro Curve table screen.

If you have an optional pressure sensor, you can also adjust the 2-point pressure calibration curve by choosing the Pressure Curve option and pressing Enter.

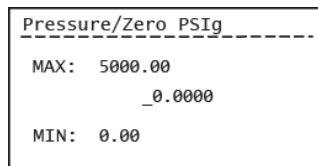
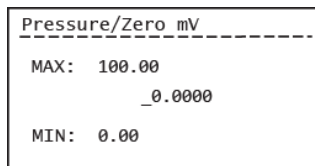

This will bring you to a display showing the 4 variables on the 2-point pressure calibration curve.

Choosing the Zero mV and pressing Enter lets you adjust the Zero mV corresponding to the Zero pressure, which can be adjusted by choosing the Zero pressure.

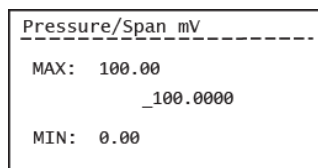
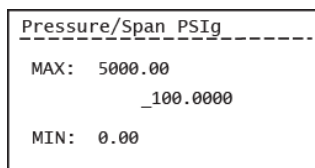

Similarly, you can also adjust the Span mV corresponding to the Span pressure.

IMPORTANT: Any changes under Settings that are not saved by pressing Enter will be lost after a time-out period of **1 minute**. The display will revert to the previous screen without the "Save Successful" intermediate screen.

Repeat the above process to enter any available CS Table data points as shown below.

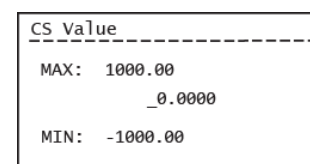
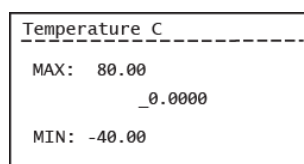
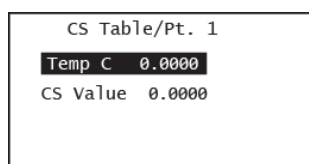
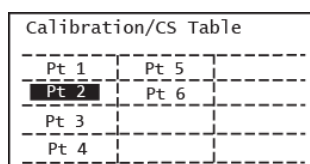

Note: The CS Table is required only if ppm_w measurements will be made. Consult Panametrics Tech Support for the table values to use for your application.

2.3.3 Changing the User Passcode

As described above the User Passcode is a generic 6-digit code (i.e., not tied to the device ID or Serial No.) with a factory (default) setting of 111111.

IMPORTANT: The only device settings locked by a device-specific Service passcode are under the Service menu (see Chapter 3). The end user can adjust all other device parameters shown in the Menu Map in Figure 16. Since the probe calibration data are protected by the User passcode, we strongly advise the end user to change the default passcode and make a note of the updated passcode.

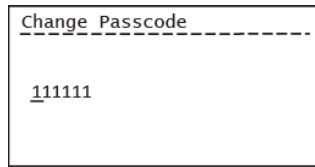
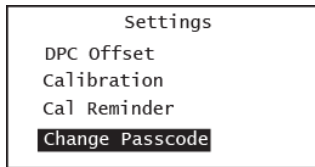

To change the User passcode choose the Change Passcode option under settings and press Enter.

The next screen lets you set the 6-digit code to any value of your choice. Press Enter to save the new passcode.

Note: The user passcode can be changed as many times as the end user wishes. The new passcode will persist through power cycling the unit.

2.3.4 Configuring HART Options

As described in Chapter 1 the HygroPro^{II} is compatible with the HART[®] 7.0 protocol and supports both point-to-point and multi-drop digital communication by superimposing low-level digital signals on top of the 4–20 mA analog output. This enables 2-way field communication between one or more HART masters the HygroPro^{II} wherein additional diagnostic information beyond the normal process variable can be communicated.

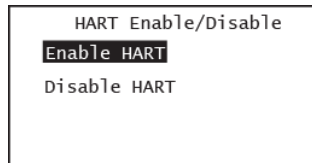
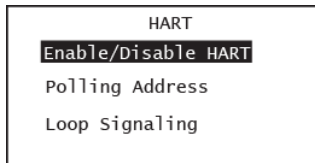

In order to configure HART settings, choose the HART option on the Main Menu and press Enter to access the HART screen.

Use the Up and Down arrow keys to select Enable/Disable HART and press Enter. The next screen shown on the left enables you to either disable (default is enabled) or enable HART on the 4 – 20 mA output. Press Enter.

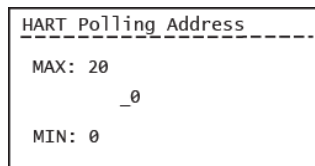
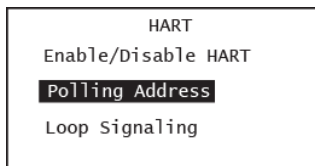

In a multi-drop configuration, each HART slave (HygroPro^{II} unit) has a unique polling address. This can be set by the Polling address option.

Pressing Enter will enable you to change this address (default = 0) between 0 and 20. Press Enter to save your selection.

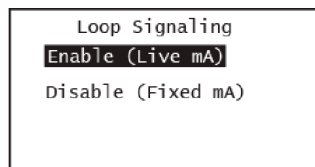

Even when HART is enabled, the 4 – 20 mA continues to work as a standard analog output that can be configured as described in Section 2.2.4 above.

To change the Loop Signaling configuration choose it and press Enter. This brings you to the next screen that lets you choose between Enable (default) and Disable. If the latter is chosen, you can set the fixed mA value for the analog output on the next screen.

2.3.5 About Display/Probe

The HygroPro^{II} has two independent components – the display and the HygroRTE probe – each with its dedicated electronics and firmware. As described in Appendix B, the display and/or probe firmware can be independently updated in the field via the RS-485 port.

```

About Menu
About Display
About Probe
Copyright Info
  
```

```

About Display
SN: 000000
FW: 6.0.0
HW: 1.0.0
Date: Sep 2022
  
```

To review the Display and/or Probe configurations, choose the About option on the Main Menu and press Enter to access the About Menu screen.

Use the Up and Down arrow keys to select About Display and press Enter. The next screen shown on the left shows the Serial no., firmware and hardware versions and the manufacturing date of the display. Press Escape to return to the About menu.

```

About Menu
About Display
About Probe
Copyright Info
  
```

```

About Probe
SN: 16036
FW: 7.0.0
HW: 1.0.0
Cal: Aug 2022
  
```

Use the Up and Down arrow keys to select About Probe and press Enter. The next screen shown on the left shows the Serial no., firmware and hardware versions and the last Calibration date of the probe. Press Escape to return to the About menu.

[no content intended for this page]

Chapter 3. Service and Maintenance

3.1 The Service Menus

IMPORTANT: The Service menus on the HygroPro^{II} are accessible only by using a unique factory-level passcode that is tied to the Serial number of your device. Please note this code is different from the User Passcode that allows for access to the Settings menu in Chapter 2. Please contact Panametrics Service to obtain this passcode for your device.

Main Menu	
No. Views	Settings
Display	Constants
Output	Service
HART	About

Enter the Passcode

000000

Service
Set Serial No.
Default
Temp Compensation

After unlocking the display (if required) and pressing **Escape** **X**, use the arrow keys to scroll to Service and press **Enter** **✓**.

The following HygroPro^{II} Service menu options are available:

1. Set Serial No. – Used to reset the Hygro^{II} RTE probe serial number that is connected to the display head.
2. Default – used to reset ALL user settings to their factory defaults.
3. Temp Compensation – Used to Enable/Disable temperature compensation of the measured Dew Point.



CAUTION! Please do NOT change the factory setting of the Serial number unless advised by Panametrics Service, as it will change the service passcode without any traceability.

The Service passcode is uniquely tied to the serial number of the probe. Please contact Panametrics Service to obtain Service Menu access.

IMPORTANT: Any changes under Service that are not saved by pressing Enter will be lost after a time-out period of 5 minutes. The display will revert to the previous screen without the “Save Successful” intermediate screen.

Select the desired Service menu option and press Enter **✓**. Then, follow the on-screen instructions.

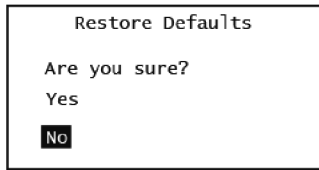
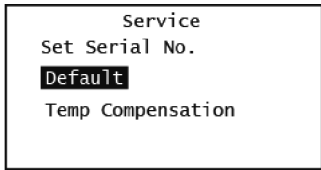

After completing the above step, respond to the “Are you sure?” question. Be sure to respond Yes, if you wish to save the new information.

Please note your input has not been accepted until the display echoes the choice selected by indicating briefly on the display, “Save Successful”.

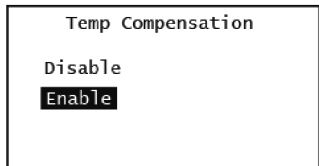
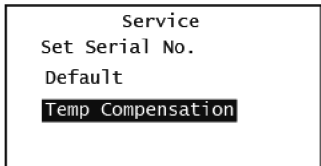

Please refer to Section 2.3.5 in the end of Chapter 2 to understand how to display the firmware, calibration, and hardware information about the HygroPro^{II} display and /or HygroRTE probe.

The firmware of the display and/or the probe can be updated in the field via the RS-485 port. Please see *Appendix B HygroPro^{II} Field Service Update* of this user manual for detailed instructions.

3.2 Moisture Probe Error Conditions

IMPORTANT: All moisture probes require periodic recalibration and cleaning to maintain optimum accuracy. Consult the Panametrics service center for the recommended probe -cleaning interval for your application.

If there is a problem with the moisture probe during operation, the HygroPro^{II} is programmed to indicate the error condition via its 4 – 20 mA analog output signal.

Note: *The NAMUR error handling scheme described below is followed only if the analog output is set to NAMUR as shown in Section 2.2.4 of Chapter 2.*

- ≥ 22 mA to indicate an Over Range error, i.e., a short circuit in the AIOx sensor on the probe
- ≤ 3.5 mA to indicate an Under Range error, i.e., an open circuit in the AIOx sensor on the probe

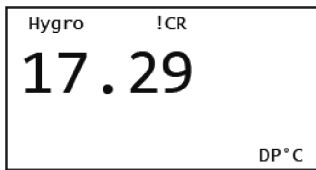

Run-time errors can also be displayed on the HygroPro^{II} LCD (in a specific pre-assigned spot) as well as by HART.

The figures on the left show the location of both the Calibration Reminder !CR error as well as the other Error codes.

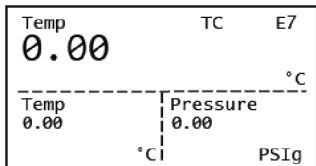

Table 7 below lists all error codes displayed HygroPro^{II} screen.

Table 7: List of error codes displayed HygroPro^{II} screen

Error Code	Description	On screen Message
E1	Error happens when probe can't be found	No Probe Error
E2	When measurement is out of the defined calibration curve range	Out of range Error
E3	When measurement is above the defined calibration curve range	Over Range Error
E4	When measurement is below the defined calibration curve range	Under Range Error
E7	This error happens when the link to the probe is dead	No Link Error
E8	The message Probe received does not have the correct CRC	Bad CRC Error
E13	The calibration curves were never entered, they have their zero default entries	No Calibration
E19	This error happens when there is a hardware fault with the moisture sensor	Hygro Sensor Fault
E20	This error happens when there is a hardware fault with the temperature sensor	Temp Sensor Fault
E21	This error happens when there is a hardware fault with the pressure sensor	Pressure Sensor Fault
E26	The ADC for the pressure measurement failed	ADC Failure

3.3 Cleaning the Moisture Probe

To clean your HygroPro^{II} moisture probe (i.e., Hygro^{II} RTE), carefully follow the instructions in this section.

3.3.1 Preparing to Clean the Probe



CAUTION! Be sure to perform the probe cleaning procedure in a well-ventilated area or laminar fume hood. Observe all necessary safety precautions when handling the cleaning solvents.

To clean the moisture probe, the following items are required:

- Two glass (**NOT** metal) containers with approximately 300 ml of reagent-grade Hexane or Toluene in each container.
- One glass (**NOT** metal) container with approximately 300 ml of distilled (NOT deionized) water.

IMPORTANT: Make sure the containers are deep enough to completely submerge the moisture probe after it is disconnected from the display head. Do not place the transmitter module into any of these solvents. Insert only the moisture sensor mounted on the probe into the solvents.

- Rubber or latex gloves
- An oven set at 50°C ± 2°C (122°F ± 3.6°F)
- 1-1/8" wrench

3.3.2 Replacing the RTE

To maximize HygroPro^{II} performance, Panametrics recommends recalibration of the aluminum oxide moisture sensor on the Replaceable Transducer Element (RTE) every 6 to 12 months. The optimum interval depends on the specific application. To accomplish this, either return the RTE to Panametrics for recalibration or install a new RTE. The HygroPro^{II} electronics will automatically read and store the calibration data whenever a new or recalibrated RTE is installed.

IMPORTANT: The factory programmed probe calibration data should not be modified without consulting Panametrics.

3.3.3 Removing the Transmitter from the System

Complete the following steps to remove the transmitter from the installation site:

1. Refer to Figure 2 on page 2 and use a 1-1/8" wrench on the probe hex nut to unthread the transmitter from the fitting on the sample system or process line.
2. Record the dew point of the ambient air.
3. Disconnect the cable from the transmitter module.



Figure 17: Step-by-step removal of the Hygro^{II} RTE probe from the transmitter

3.3.4 Removing the Probe from the Transmitter

The Hygro^{II} RTE probe is easy to remove from the dismantled transmitter by loosening the two shoulder screws and disconnecting the internal M8 connector cable as shown in Figure 18 below. To remove the probe from the transmitter, refer to Figure 17 above and proceed as follows:

1. Loosen the two captive shoulder screws just below the transmitter display above the hex head of probe.
2. Carefully loosen these screws until the probe assembly can rotate without any resistance within the display head.
3. Carefully pull the probe out of the transmitter while ensuring the two O-rings stay in their glands.
4. Disconnect the M8 connector of the internal yellow probe cable by turning the locknut at the top of the probe. Then, detach the probe (see Figure 18).

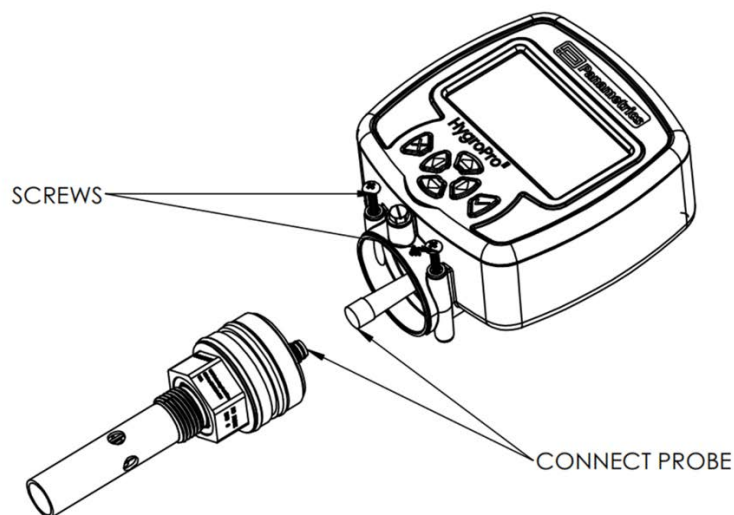

Figure 18: Removing the Hygro^{II} RTE probe from the transmitter

3.3.5 Cleaning the Sensor and the Shield



CAUTION! Do not place the display head/transmitter module into any of the solvents. Insert only the sensor portion of the probe. Do not allow the Aluminum Oxide sensor to come into contact with the surfaces of cleaning containers or with any other hard surface.

1. While wearing protective gloves, place the sensors on the probe in the first container of Hexane or Toluene and allow them to soak for 10 minutes.
2. Remove the sensors from the Hexane or Toluene and soak them in the container of distilled water for 10 minutes.
3. Remove the sensors from the distilled water and soak them in the second (clean) container of Hexane or Toluene for 10 minutes.
4. Remove the sensors from the Hexane or Toluene and set the probe aside in a clean area.
5. Repeat steps 1 to 3 to clean the shield. To ensure the removal of any contaminants that may have stuck to the walls of the shield, swirl the shield in the solvents during the soaking procedure.
6. Remove the shield from the Hexane or Toluene.
7. Carefully replace the shield over the exposed sensors without touching them.
8. Place the probe, i.e., cleaned sensors with the installed shield, in an oven set at $50^{\circ}\text{C} \pm 2^{\circ}\text{C}$ ($122^{\circ}\text{F} \pm 3.6^{\circ}\text{F}$) for 24 hours.

3.3.6 Installing the Probe in the Transmitter



CAUTION! Please check both the probe sealing O-rings (2X Silicone) and the process sealing O-ring (Viton) on the probe mount prior to installing or re-installing a HygroPro^{II} into the process. These transmitters should be supplied with a new process O-ring after each recalibration to ensure safe and reliable process seal.

To install a new, recalibrated or cleaned probe back in the transmitter, see Figure 19 below. This procedure requires completing the following steps:

1. Ensure the two shoulder screws at the bottom of the display head are fully loosened.
2. Reconnect the M8 probe cable to the top connected of the probe by turning the locknut.
3. Carefully push the probe into the transmitter while gently twisting it clockwise when looking from the shield end.
4. Ensure that the probe is properly seated in its slot without either O-ring protruding from the bottom of the display head.
5. Tighten the two captive shoulder screws all the way into their slots at the bottom of the display head.



Figure 19: Reinstalling the Hygro^{II} RTE probe into the dismantled transmitter

3.3.7 Evaluating the Cleaned Probe

Note: *All new probes are calibrated at the factory, and therefore, no evaluation is required after installation.*

1. Reconnect the probe cable to the transmitter module and measure the ambient air dew point. Make sure to measure the same ambient air as measured during removal of the transmitter.
2. Compare the two ambient air readings. If the new ambient air reading is within $\pm 2^{\circ}\text{C}$ ($\pm 3.6^{\circ}\text{F}$) of the first reading, the cleaned probe is properly calibrated and normal operation may be resumed.
3. If the probe is still not reading the ambient air accurately, repeat the cleaning procedure using soaking times that are five times those used in the previous cleaning sequence. Repeat the cleaning cycles until two consecutive ambient air readings are identical.

If the above cleaning procedure does not result in accurate readings, contact Panametrics Technical Support for assistance.

Chapter 4. Specifications

4.1 General

Dew Point/Frost Point Calibration Range

- -80°C to $+10^{\circ}\text{C}$ (-112°F to 50°F) standard with data from -110°C to $+20^{\circ}\text{C}$ (-166°F to 68°F)

Operating/Storage Temperature

- -20°C to 60°C (-4°F to 140°F) operating temperature
- -20°C to 60°C (-4°F to 140°F) process temperature
- -40°C to 70°C (-40°F to 158°F) storage temperature

Warm-Up Time

- Meets specified accuracy within three minutes after initial power up

Calibrated Accuracy (Dew/Frost Point)

- $\pm 3.6^{\circ}\text{F}$ ($\pm 2^{\circ}\text{C}$) above -148°F (-100°C)
- $\pm 5.4^{\circ}\text{F}$ ($\pm 3^{\circ}\text{C}$) below -148°F (-100°C)

Repeatability (Dew/Frost Point)

- $\pm 0.4^{\circ}\text{F}$ ($\pm 0.2^{\circ}\text{C}$) above -148°F (-100°C)
- $\pm 0.9^{\circ}\text{F}$ ($\pm 0.5^{\circ}\text{C}$) below -148°F (-100°C)

4.2 Electrical

Power

- *Input:* 12 to 28 VDC (loop-powered, customer supplied)
- *Outputs:* 4 to 20 mA analog, HART and RS-485 digital
- *Output Resolution:* 0.01 mA/12 bits
- *Maximum Load Resistance:* $RL = (PSV \times 33.33) - 300$, where PSV = Power Supply Voltage
Example: Given a 24 VDC Power Supply, Max. Load Resistance = $(24 \times 33.33) - 300 = 500\Omega$
- *Cable:* Shielded 4-conductor 6 ft. (2 m) and 30 ft. (10 m), standard (consult Panametrix for custom lengths)

Input Parameters for Loop-Powered Intrinsic Safety:

Loop Power Supply		
$U_i = 28 \text{ V}$	$P_i = 0.7 \text{ W}$	$L_i = 0 \mu\text{H}$
$I_i = 100 \text{ mA}$	$C_i = 0 \mu\text{F}$	
RS-485 Digital Output		
$U_i = 4.0 \text{ V}$	$P_i = 250 \text{ mW}$	$L_i = 0 \mu\text{H}$
$I_i = 250 \text{ mA}$	$C_i = 0 \mu\text{F}$	

4.3 Mechanical

Sample Connection

- 3/4-16 (19 mm) straight male thread with O-ring
- G ½ with optional adapter

Operating Pressure

- 5 µm Hg to 5,000 psig (345 bar)

Enclosure

- Type 4x, IP 66, IP67

Dimensions

- Overall (H x W x D): 7.88 x 3.99 x 2.56 in. (200 x 101 x 65 mm)
- Weight: 1.2 lb (550 g)

4.4 Moisture Sensor

Sensor Type

- Thin-film aluminum oxide moisture sensor probe

Calibration

- Each sensor is individually computer-calibrated against known moisture concentrations, traceable to NIST Calibration

Interval

- Sensor recalibration at Panametrics is recommended every six to twelve months, depending on the application

Flow Rate

- *Gases*: Static to 100 m/s linear velocity at a pressure of 1 atm.
- *Liquids*: Static to 10 cm/s linear velocity at density of 1 g/cc

4.5 Built-In Temperature Sensor

Type

- Nonlinear NTC thermistor (resultant temperature linearized by microprocessor)

Measurement Range

- -22° to 158°F (-30° to 70°C)

Accuracy

- ±0.9°F (±0.5°C) overall

4.6 Built-In Pressure Sensor

Type

- Solid-state, Piezo resistive

Available Ranges

- 30 to 300 psig (3 to 21 bar)
- 50 to 500 psig (4 to 35 bar)
- 100 to 1000 psig (7 to 69 bar)
- 300 to 3000 psig (21 to 207 bar)
- 500 to 5000 psig (35 to 345 bar)

Note: PSIG ranges are based on a constant pressure, with the value provided at the time of order placement.

Accuracy

- $\pm 1\%$ of full scale (FS)

Warm-up Time

- Meets specified accuracy within 3 minutes

Pressure Rating

- Three times the span of the available range, to a maximum of 7500 psig (518 bar)

4.7 Certifications

European Compliance

- Complies with EMC Directive 2004/108/EC and PED 2006/95/EC for DN<25

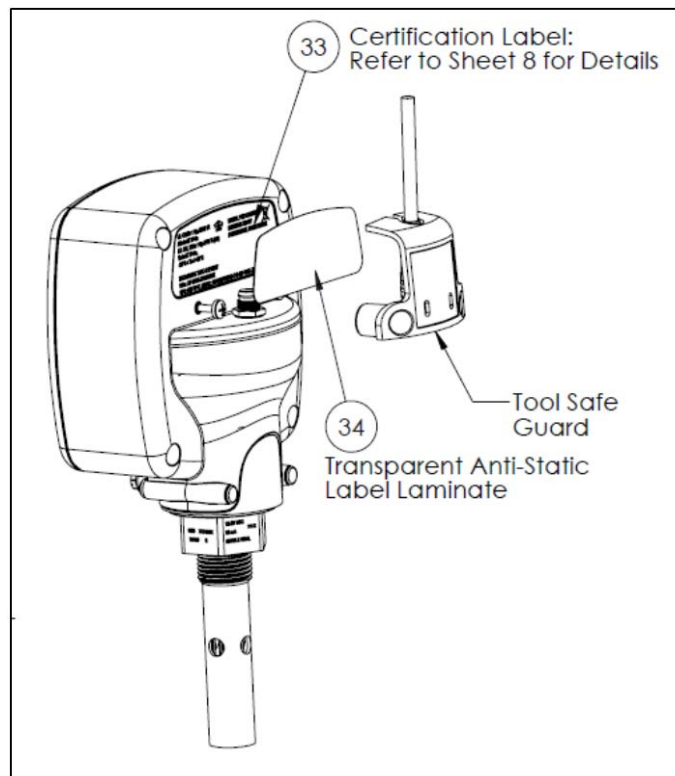

Figure 20: HygroPro^{II} Certification Label

[no content intended for this page]

Appendix A. HygroPro^{II} HART[®] Field Device Specification

A.1 Introduction

A.1.1 Scope

The Baker Hughes Panametrics HygroPro^{II} moisture transmitter, revision 1 complies with HART Protocol Revision 7.5. This document specifies all the device specific features and documents HART Protocol implementation details (e.g., the Engineering Unit Codes supported). The functionality of this Field Device is described sufficiently to allow its proper application in a process and its complete support in HART capable host applications.

A.1.2 Purpose

This specification is designed to complement other documentation by providing a complete, unambiguous description of this Field Device from a HART Communication perspective.

A.1.3 Who should use this document?

The specification is designed to be a technical reference for HART capable host application developers, system integrators and knowledgeable end users. It also provides functional specifications (e.g., commands, enumerations and performance requirements) used during Field Device development, maintenance and testing. This document assumes the reader is familiar with HART Protocol requirements and terminology.

A.1.4 Abbreviations and definitions

ADC	Analog to Digital Converter
CPU	Central Processing Unit (of microprocessor)
DAC	Digital to Analog Converter
EEPROM	Electrically-Erasable Read-Only Memory
ROM	Read-Only Memory
MPU	Measurement Process Unit

A.1.5 References

- *HART Field Communication Protocol Specification*. HCF_SPEC-13.
- *FSK Physical Layer Specification*. HCF_SPEC-54.
- *Data Link Layer Specification*. HCF_SPEC-81.
- *Command Summary Specification*. HCF_SPEC-99.
- *Universal Command Specification*. HCF_SPEC-127.
- *Common Practice Command Specification*. HCF_SPEC-151.
- *Device Families Command Specification*. HCF_SPEC-160.
- *Common Tables Specification*. HCF_SPEC-183.

A.2 Device Identification

Manufacturer Name:	Baker Hughes Panametrics	Model Name(s):	HygroPro ^{II}
Manufacture ID Code:	157 (0x9D Hex)	Device Type Code:	121 (0x79 Hex)
HART Protocol Revision	7.6	Device Revision:	2
Number of Device Variables	104		
Physical Layers Supported	FSK		
Physical Device Category	Current Output		

The Panametrics HygroPro^{II} transmitter is housed in a plated, Zinc alloy, IP66/IP 67 rated enclosure suitable for both indoor and outdoor use. The product certification label is located on the back side of the enclosure and indicates the model name and serial number. Revision information is shown on the LCD when the meter is energized.

A.3 Product Overview

The Panametrics HygroPro^{II} transmitter is a new transmitter platform, with a 4-to-20mA output.

Any programmable logic controller (PLC), distributed control system (DCS) or other process control console configured to multiplex HART digital data on a 4-to-20-mA analog signal can read all available measurements, computations and diagnostics.

A.4 Product Interfaces

A.4.1 Process Interface

A.4.1.1 Sensor Input Channels

A single removable transducer element (moisture probe) is connected to the device. Refer to the manuals for connection instructions.

A.4.2 Host interface

A.4.2.1 Analog Output

There is a single 4-20mA output from the Panametrics HygroPro^{II} transmitter and HART is supported on it.

A.4.2.2 Digital Output

There is one RS 485 digital output channel on the Panametrics HygroPro^{II} transmitter.

A.4.3 Local Interfaces, Jumpers and Switches

A.4.3.1 Local Controls and Displays

A 128X64 LCD and six-button keypad facilitate programming at the device.

A.4.3.2 Internal Jumpers and Switches

The Panametrics HygroPro^{II} transmitter has a write-enable switch to allow "write" and "command" commands to execute.

A.5 Device Variables

The device Variables are showed below.

Measurement	Device Variable code	Device Variable Classification Code	
		Code	Classification
Dew Point Degrees C	0	0	Moisture
Dew Point Degrees F	1	0	Moisture
Parts Per Million Volume (PPMv)	2	0	Moisture
Parts Per Million Volume (PPBv)	3	0	Moisture
Parts Per Million Volume Natural Gas (PPMvNG)	4	0	Moisture
mg/m3	5	0	Moisture
g/m3	6	0	Moisture
kg/m3	7	0	Moisture
LBs/MMSCFig	8	0	Moisture
LBs/MMSCFng	9	0	Moisture
FH	10	0	Moisture
Temperature deg C	11	64	Temperature
Temperature deg F	12	64	Temperature
Temperature deg K	13	64	Temperature
Temperature deg R	14	64	Temperature
Pressure PSig	15	65	Pressure
Pressure PSla	16	65	Pressure
Pressure Bars	17	65	Pressure
Pressure mbs	18	65	Pressure
Pressure mmHg	19	65	Pressure
Pressure Pa	20	65	Pressure
Pressure KPa	21	65	Pressure
Pressure mV	22	65	Pressure

Dynamic Variables

The following device variables listed in the table can be used as Primary Variable (PV):

0, 1, 2, 3

Any device variable listed in the table may be assigned as secondary variables (SV), tertiary variables (TV) or quaternary variables (QV).

A.6 Status Information

A.6.1 Device Status

Bit 4 ("More Status Available") is set whenever any failure is detected. Command #48 gives further detail.

A.6.2 Extended Device Status

- Code 0x01, Maintenance Required, is never set by the Panametrics HygroPro^{II} transmitter.
- Code 0x02, Device Variable Alert, is never set by the Panametrics HygroPro^{II} transmitter.
- Code 0x04, Critical Power Failure, is never set by the Panametrics HygroPro^{II} transmitter.

A.6.3 Additional Device Status (Command #48)

Command #48 returns 25 bytes of data, with the following status information:

HART Additional Device Status				
Byte	Bit	Error Description	Class	Device Status Bits Set
0	0	Reserved	Warning	4, 7
	1	No Probe Error	Error	4, 7
	2	Out of Range Error	Error	4, 7
	3	Over Range Error	Error	4, 7
	4	Under Range Error	Error	4, 7
	5	No Link Error	Error	4, 7
	6	Bad CRC Error	Error	4, 7
	7	No Cal. Error	Error	4, 7
1	0	Hygro Fault	Error	4, 7
	1	Temperature Fault	Error	4, 7
	2	Pressure Fault	Error	4, 7
	3	ADC Failure	Error	4, 7
	4	Reserved	Error	4, 7
	5	Reserved	Error	4, 7
	6	Reserved	Error	4, 7
	7	Reserved	Error	4, 7
2	0	Reserved	Error	4, 7
	1	Reserved	Error	4, 7
	2	Reserved	Error	4, 7
	3	Reserved	Error	4, 7
	4	Reserved	Error	4, 7
	5	Reserved	Error	4, 7
	6	Reserved	Error	4, 7
	7	Reserved	Error	4, 7

HART Additional Device Status				
Byte	Bit	Error Description	Class	Device Status Bits Set
3	0	Reserved	Error	4, 7
	1	Reserved	Error	4, 7
	2	Reserved	Error	4, 7
	3	Reserved	Error	4, 7
	4	Reserved	Error	4, 7
	5	Reserved	Error	4, 7
	6	Reserved	Error	4, 7
	7	Active TW error	Error	4, 7

Bytes 4 & 5 are reserved for future use, Byte 4 is for generic warnings, Byte 5 for generic failures.

Byte 6 is the Extended Device Status, which, as stated above, the Panametrics HygroPro^{II} never sets and are always 0.

Byte 7 is for the Device Operating Mode, the Panametrics HygroPro^{II} only has one operating mode and as such does not use this byte, all bits are 0.

Bytes 8, 9, 11, and 12 are standardized status bits that the Panametrics HygroPro^{II} does not make use of, they are all 0.

Byte 10 is the Analog Channel Saturated Byte, if the Loop Current is saturated the lowest bit will read 1, otherwise all bits are 0.

Byte 13 is the Analog Channel Fixed Byte, if the loop current is fixed then the lowest bit will read 1, otherwise all bits are 0.

"Reserve/Not used" bits are always set to 0. These bits are set or cleared by the self-test executed at power up, or following a reset. They are also set (but not cleared) by any failure detected during continuous background self-testing.

A.7 Universal Commands

Command	Function	Description
0	Read Unique Identifier	Returns identity information about the meter including: the Device Type, revision levels, and Device ID.
1	Read Primary Variable	Returns the Primary Variable value along with its Unit Code
2	Read Loop Current And Percent Of Range	Reads the Loop Current and its associated Percent of Range.
3	Read Dynamic Variables and Loop Current	Reads the Loop Current and up to four predefined Dynamic Variables. The Dynamic Variables and associated units are defined via Commands 51 and 53.
6	Write Polling Address	Writes the polling address and the loop current mode to the field device.
7	Read Loop Configuration	Read polling address and the loop current mode.
8	Read Dynamic Variable Classification	Reads the Classification associated with the Dynamic variable.
9	Read Device Variables with Status	Request the value and status of up to eight device Device or Dynamic Variables.
11	Read Unique Identifier Associated With Tag	If the specified tag matches that of the meter, it responds with the Command 0 response.
12	Read Message	Reads the Message contained within the meter.
13	Read Tag, Descriptor, Date	Reads the Tag, Descriptor, and Date contained within the meter.
14	Read Primary Variable Transducer Information	Reads the Transducer (meter) Serial Number, Limits/Minimum Span Units Code, Upper Transducer Limit, Lower Transducer Limit, and Minimum Span for the Primary Variable transducer.
15	Read Device Information	Reads the alarm selection code, transfer function code, range values units code upper range value, Primary Variable lower range value, damping value, write protect code, and private label distributor code.
16	Read Final Assembly Number	Reads the Final Assembly Number associated with the meter.
17	Write Message	Write the Message into the meter.
18	Write Tag, Descriptor, Date	Write the Tag, Descriptor, and Date Code into the meter.
19	Write Final Assembly Number	Write the Final Assembly Number into the meter.
20	Read Long Tag	Read the 32-byte Long Tag.
21	Read Unique Identifier Associated with Long Tag	Read Unique Identifier Associated with Long Tag
22	Write Long Tag	Write the 32-byte Long Tag
38	Reset Configuration Changed Flag	Resets the configuration changed indicator (Device Status Byte bit 6).
48	Read Additional Device Status	Returns meter status information not included in the Response Code or Device Status Byte.

A.8 Common-Practice Commands

A.8.1 Supported Commands

Command	Function	Description
33	Read Device Variables	Allows a Master to request the value of up to four Device Variables.
50	Read Dynamic Variable Assignments	Reads the Device Variables assigned to the Primary, Secondary, Tertiary, and Quaternary Variables.
51	Write Dynamic Variable Assignments	Allows the user to assign Device Variables to the Primary, Secondary, Tertiary, and Quaternary Variables
54	Read Device Variable Information	Get device variable information
59	Write Number of Response Preambles	Sets the number of asynchronous preamble bytes to be sent by the meter before the start of a response message.

A.8.2 Burst Mode

This Field Device does not support Burst Mode.

A.8.3 Catch Device Variable

This Field Device does not support Catch Device Variable.

A.9 Device-Specific Commands

The following device-specific commands are implemented:

- Command 130 (0x82): Set Loop Current Zero
- Command 131 (0x83): Set Loop Current Gain
- Command 132 (0x84): Set Loop Current Percentage
- Command 133 (0x85): Set Primary Variable Range Values
- Command 134 (0x86): Set Loop Current Error Handling
- Command 140 (0x8C): Read Primary Variable Range Values
- Command 141 (0x8D): Read Loop Current Error Handling
- Command 144 (0x90): Set Loop Measurement Type
- Command 145 (0x91): Enter / Exit Fixed Loop Current
- Command 146 (0x92): Set Pressure Constant
- Command 147 (0x93): Read Pressure Constant
- Command 148 (0x94): Set Temperature Constant
- Command 149 (0x95): Read Temperature Constant
- Command 150 (0x96): Set Dew Point Offset
- Command 151 (0x97): Read Dew Point Offset
- Command 152 (0x98): Set Hygro Curve Number of Points
- Command 153 (0x99): Read Hygro Curve Number of Points
- Command 154 (0x9A): Set Hygro Curve
- Command 155 (0x9B): Read Hygro Curve
- Command 156 (0x9C): Set Pressure Curve
- Command 157 (0x9D): Read Pressure Curve
- Command 158 (0x9E): Set Saturation TableNumber of Points

- Command 159 (0x9F): Read Saturation Table Number of Points
- Command 160 (0xA0): Set Saturation Table Point
- Command 161 (0xA1): Read Saturation Table Point
- Command 162 (0xA2): Set Temperature Coefficients
- Command 163 (0xA3): Read Temperature Coefficients
- Command 192 (0xA4): Sends password
- Command 193 (0xA5): Sends new password
- Command 194 (0xA6): Read User Level
- Command 197 (0xA7): Commit the changed parameter
- Command 198 (0xA8): Cancel the changed parameter

A.9.1 Command 130 (0x82): Set Loop Trim Zero

This command is to trim the zero or low endpoint value to a value of 4 mA. For example, if the zero value is 4.1 mA, then the correction entered should be -0.1 mA to achieve a result of 4 mA.

Request Data Bytes

Byte	Format	Description
0	Unsigned-8	Enumeration. 0 = Fixed 4 mA trim, 1 = Live mA Set for live analog output or fixed 4 mA for trim purposes
1~4	Float	mA correction value

Response Data Bytes

Byte	Format	Description
0	Unsigned-8	Enumeration. 0 = Fixed 4 mA trim, 1 = Live mA Set for live analog output or fixed 4 mA for trim purposes
1~4	Float	mA correction value

Command-Specific Response Codes

Code	Class	Description
0	Success	No Command-Specific Errors
1-2		Undefined
3	Error	Passed Parameter Too Large
4	Error	Passed Parameter Too Small
5	Error	Too Few Data Bytes Received
6	Error	Device-Specific Command Error
7	Error	In Write Protect Mode
8 ~ 10		Undefined
11	Error	Loop Current Not Active
12 ~ 15		Undefined
16	Error	Access Restricted
17-31		Undefined

Code	Class	Description
32	Error	Busy
33 ~ 127		Undefined

A.9.2 Command 131 (0x83): Set Loop Current Gain

This command is to trim the zero or low endpoint value to a value of 4 mA. For example, if the zero value is 4.1 mA, then the correction entered should be -0.1 mA to achieve a result of 4 mA.

Request Data Bytes

Byte	Format	Description
0	Unsigned-8	Enumeration. 0 = Fixed 20 mA trim, 1 = Live mA Set for live analog output or fixed 20 mA for trim purposes
1~4	Float	mA correction value

Response Data Bytes

Byte	Format	Description
0	Unsigned-8	Enumeration. 0 = Fixed 20 mA trim, 1 = Live mA Set for live analog output or fixed 20 mA for trim purposes
1~4	Float	mA correction value

Command-Specific Response Codes

Code	Class	Description
0	Success	No Command-Specific Errors
1-2		Undefined
3	Error	Passed Parameter Too Large
4	Error	Passed Parameter Too Small
5	Error	Too Few Data Bytes Received
6	Error	Device-Specific Command Error
7	Error	In Write Protect Mode
8		Undefined
9	Error	Incorrect Loop Current Mode or Value
10		Undefined
11	Error	Loop Current Not Active
12 ~ 15		Undefined
16	Error	Access Restricted
17-31		Undefined
32	Error	Busy
33 ~ 127		Undefined

A.9.3 Command 132 (0x84): Set Loop Current Percentage

This command is to set the output percentage of loop 1 current.

This command sets the output to a user determined percent of the 4-20 mA output.
Examples: 0 pct = 4 mA, 50% = 12 mA, and 100% = 20 mA.

Request Data Bytes

Byte	Format	Description
0	Unsigned-8	Enumeration. 0 = Fixed percent test, 1 = Live mA Sets live analog output or fixed mA value
1~4	Float	Loop Current Percentage, units of percent.

Response Data Bytes

Byte	Format	Description
0	Unsigned-8	Enumeration. 0 = Fixed percent test, 1 = Live mA Sets live analog output or fixed mA value
1~4	Float	Loop Current Percentage, units of percent.

Command-Specific Response Codes

Code	Class	Description
0	Success	No Command-Specific Errors
1-2		Undefined
3	Error	Passed Parameter Too Large
4	Error	Passed Parameter Too Small
5	Error	Too Few Data Bytes Received
6	Error	Device-Specific Command Error
7	Error	In Write Protect Mode
8		Undefined
9	Error	Incorrect Loop Current Mode or Value
10		Undefined
11	Error	Loop Current Not Active
12 ~ 15		Undefined
16	Error	Access Restricted
17-31		Undefined
32	Error	Busy
33 ~ 127		Undefined

A.9.4 Command 133 (0x85): Set Primary Variable Range Values

This command is to set the PV range.

Request Data Bytes

Byte	Format	Description
0	Unsigned-8	Upper and Lower Range Values Unit Class
1	Unsigned-8	Upper and Lower Range Values Unit Code
2 ~ 5	Float	Upper Range Value
6 ~ 9	Float	Lower Range Value

Response Data Bytes

Byte	Format	Description
0	Unsigned-8	Upper and Lower Range Values Unit Class
1	Unsigned-8	Upper and Lower Range Values Unit Code
2 ~ 5	Float	Upper Range Value
6 ~ 9	Float	Lower Range Value

Command-Specific Response Codes

Code	Class	Description
0	Success	No Command-Specific Errors
1		Undefined
2	Error	Invalid Selection
3 ~ 4		Undefined
5	Error	Too Few Data Bytes Received
6	Error	Device-Specific Command Error
7	Error	In Write Protect Mode
8	Warning	Set To Nearest Possible Value (Upper or Lower Range Pushed)
9	Error	Lower Range Value Too High
10	Error	Lower Range Value Too Low
11	Error	Upper Range Value Too High
12	Error	Upper Range Value Too Low
13	Error	Upper and Lower Range Values Out Of Limits
14	Warning	Span Too Small
15		Undefined
16	Error	Access Restricted
17		Undefined
18	Error	Invalid Units Code
19 -28		Undefined
29	Error	Invalid Span
30 ~ 31		Undefined

Code	Class	Description
32	Error	Busy
33 ~ 127		Undefined

A.9.5 Command 140 (0x8C): Read Primary Variable Range Values

This command is to read the PV range.

Request Data Bytes

Byte	Format	Description
None		

Response Data Bytes

Byte	Format	Description
0	Unsigned-8	Upper and Lower Range Values Unit Class
1	Unsigned-8	Upper and Lower Range Values Unit Code
2 ~ 5	Float	Upper Range Value
6 ~ 9	Float	Lower Range Value

Command-Specific Response Codes

Code	Class	Description
0	Success	No Command-Specific Errors
1 ~ 127		Undefined

A.9.6 Command 144 (0x90): Set Loop Measurement Type

This command is to set the loop measurement type to 1 of 3 enumerations:

0 – 4–20 mA, 1 – NAMUR, 2 – Special Zero and Span Values

When the loop measurement type is set to Special, then the Special span value and special zero value will determine the endpoint mA values instead of 4 mA and 20 mA.

Request Data Bytes

Byte	Format	Description
0	Unsigned-8	Loop Measurement type
1~4	Float	Special Zero Value
5~8	Float	Special Span Value

Response Data Bytes

Byte	Format	Description
0	Unsigned-8	Loop Measurement type

1~4	Float	Special Zero Value
5~8	Float	Special Span Value

Command-Specific Response Codes

Code	Class	Description
0	Success	No Command-Specific Errors
1		Undefined
2	Error	Invalid Selection
3-4		Undefined
5	Error	Too Few Data Bytes Received
6	Error	Device-Specific Command Error
7	Error	In Write Protect Mode
8 ~ 15		Undefined
16	Error	Access Restricted
17-127		Undefined

A.9.7 Command 146 (0x92): Set Pressure Constant

This sets the pressure constant to substitute for real pressure measurement. First byte is an enumeration: 0 = pressure constant active, 1 = live measurement instead of constant

Request Data Bytes

Byte	Format	Description
0	Unsigned-8	0 = use constant 1 = use live
1~4	Float	Pressure constant to substitute for real pressure measurement.

Response Data Bytes

Byte	Format	Description
0	Unsigned-8	0 = use constant 1 = use live
1~4	Float	Pressure constant to substitute for real pressure measurement.

Command-Specific Response Codes

Code	Class	Description
0	Success	No Command-Specific Errors
1-4		Undefined
5	Error	Too Few Data Bytes Received
6	Error	Device-Specific Command Error
7	Error	In Write Protect Mode
8-15		Undefined

Code	Class	Description
16	Error	Access Restricted
8-127		Undefined

A.9.8 Command 147 (0x93): Read Pressure Constant

This command reads the pressure constant used in place of a live pressure measurement. First byte is an enumeration: 0 = pressure constant active, 1 = live measurement instead of constant

Request Data Bytes

Byte	Format	Description
None		

Response Data Bytes

Byte	Format	Description
0	Unsigned-8	0 = use constant 1 = use live
1 ~ 4	Float	Pressure constant used instead of live measurement.

Command-Specific Response Codes

Code	Class	Description
0	Success	No Command-Specific Errors
1-127		Undefined

A.9.9 Command 148 (0x94): Set Temperature Constant

Sets a temperature constant to be used in place of a live measurement. First byte is an enumeration: 0 = temperature constant active, 1 = live measurement instead of constant

Request Data Bytes

Byte	Format	Description
0	Unsigned-8	0 = use constant 1 = live
1~4	Float	Temperature constant value.

Response Data Bytes

Byte	Format	Description
0		0 = use constant 1 = live
1~4	Float	Temperature constant value.

Command-Specific Response Codes

Code	Class	Description
0	Success	No Command-Specific Errors
1-4		Undefined
5	Error	Too Few Data Bytes Received
6	Error	Device-Specific Command Error
7	Error	In Write Protect Mode
8-15		Undefined
16	Error	Access Restricted
8-127		Undefined

A.9.10 Command 149 (0x95): Read Temperature Constant

Reads the temperature constant used instead of the live measurement.
First byte is an enumeration: 0 = temperature constant active, 1 = live measurement instead of constant

Request Data Bytes

Byte	Format	Description
None		

Response Data Bytes

Byte	Format	Description
0	Unsigned-8	0 = use constant 1 = live
1 ~ 4	Float	Temperature constant used instead of live measurement.

Command-Specific Response Codes

Code	Class	Description
0	Success	No Command-Specific Errors
1-127		Undefined

A.9.11 Command 150 (0x96): Set Dew Point Offset

This command will set the Dew Point Offset adjustment.

Request Data Bytes

Byte	Format	Description
0	Float	Dew Point offset adjustment.

Response Data Bytes

Byte	Format	Description
0~3	Float	Dew Point offset adjustment.

Command-Specific Response Codes

Code	Class	Description
0	Success	No Command-Specific Errors
1-4		Undefined
5	Error	Too Few Data Bytes Received
6	Error	Device-Specific Command Error
7	Error	In Write Protect Mode
8-15		Undefined
16	Error	Access Restricted
8-127		Undefined

A.9.12 Command 151 (0x97): Read Dew Point Offset

Reads the Dew Point offset adjustment.

Request Data Bytes

Byte	Format	Description
None		

Response Data Bytes

Byte	Format	Description
0 ~ 3	Float	Dew Point offset adjustment.

Command-Specific Response Codes

Code	Class	Description
0	Success	No Command-Specific Errors
1-127		Undefined

A.9.13 Command 152 (0x98): Set Number of Hygro Calibration Points

This command will set the number of points for the Hygro. Curve.

Request Data Bytes

Byte	Format	Description
0	Unsigned-8	Number of Hygro Calibration Points

Response Data Bytes

Byte	Format	Description
0	Unsigned-8	Number of Hygro Calibration Points

Command-Specific Response Codes

Code	Class	Description
0	Success	No Command-Specific Errors
1	Error	Number of points out of range.
2-4		Undefined
5	Error	Too Few Data Bytes Received
6	Error	Device-Specific Command Error
7	Error	In Write Protect Mode
8-15		Undefined
16	Error	Access Restricted
8-127		Undefined

A.9.14 Command 153 (0x99): Read Number of Hygro Calibration Points

Reads the Dew Point offset adjustment.

Request Data Bytes

Byte	Format	Description
None		

Response Data Bytes

Byte	Format	Description
0	Unsigned-8	Number of Hygro Calibration Points.

Command-Specific Response Codes

Code	Class	Description
0	Success	No Command-Specific Errors
1-127		Undefined

A.9.15 Command 154 (0x9A): Read Hygro Calibration Curve

This command is to read a selected Hygro Calibration Point.

Request Data Bytes

Byte	Format	Description
0	Unsigned-8	Index of Hygro curve point.

Response Data Bytes

Byte	Format	Description
0	Unsigned-8	Index of Hygro curve point.
1 ~ 2	Signed-16	Dew Point Value of point.
3 ~ 6	Float	FH value of point.

Command-Specific Response Codes

Code	Class	Description
0	Success	No Command-Specific Errors
1	Error	Index Out of Bounds.
2 ~ 127		Undefined

A.9.16 Command 155 (0x9B): Write Hygro Calibration Curve

This command is to read the loop 0 current output error handling.

Request Data Bytes

Byte	Format	Description
0	Unsigned-8	Index of Hygro curve point.
1 ~ 2	Signed-16	Dew Point Value of point.
3 ~ 6	Float	FH value of point.

Response Data Bytes

Byte	Format	Description
0	Unsigned-8	Index of Hygro curve point.
1 ~ 2	Signed-16	Dew Point Value of point.
3 ~ 6	Float	FH value of point.

Command-Specific Response Codes

Code	Class	Description
0	Success	No Command-Specific Errors
1-3		Undefined
4	Error	Index Out of Bounds Error.
5	Error	Too Few Data Bytes Received
6	Error	Device-Specific Command Error
7	Error	In Write Protect Mode
8-15		Undefined
16	Error	Access Restricted
8-127		Undefined

A.9.17 Command 156 (0x9C): Set Pressure Curve

This command sets the two point pressure curve.

Request Data Bytes

Byte	Format	Description
0 ~ 3	Float	Low End mV
4 ~ 7	Float	Low End PSig
8 ~ 11	Float	High End mV
12 ~ 15	Float	High End PSig

Response Data Bytes

Byte	Format	Description
0 ~ 3	Float	Low End mV
4 ~ 7	Float	Low End PSig
8 ~ 11	Float	High End mV
12 ~ 15	Float	High End PSig

Command-Specific Response Codes

Code	Class	Description
0	Success	No Command-Specific Errors
1-4		Undefined
5	Error	Too Few Data Bytes Received
6	Error	Device-Specific Command Error
7	Error	In Write Protect Mode
8-15		Undefined
16	Error	Access Restricted
8-127		Undefined

A.9.18 Command 157 (0x9D): Read Pressure Curve

This command reads the two point pressure curve.

Request Data Bytes

Byte	Format	Description
None		

Response Data Bytes

Byte	Format	Description
0 ~ 3	Float	Low End mV
4 ~ 7	Float	Low End PSig

8 ~ 11	Float	High End mV
12 ~ 15	Float	High End PSIG

Command-Specific Response Codes

Code	Class	Description
0	Success	No Command-Specific Errors
1-127		Undefined

A.9.19 Command 158 (0x9E): Set Saturation Table Number of Points

This command set the number of points for the saturation table.

Request Data Bytes

Byte	Format	Description
0	Unsigned-8	Number of Saturation Table Points

Response Data Bytes

Byte	Format	Description
0	Unsigned-8	Number of Saturation Table Points

Command-Specific Response Codes

Code	Class	Description
0	Success	No Command-Specific Errors
1	Error	Number of points out of range.
2-4		Undefined
5	Error	Too Few Data Bytes Received
6	Error	Device-Specific Command Error
7	Error	In Write Protect Mode
8-15		Undefined
16	Error	Access Restricted
8-127		Undefined

A.9.20 Command 159 (0x9F): Read Saturation Table Number of Points

This command reads the number of saturation table points.

Request Data Bytes

Byte	Format	Description
None		

Response Data Bytes

Byte	Format	Description
0	Unsigned-8	Number of Saturation Table Points.

Command-Specific Response Codes

Code	Class	Description
0	Success	No Command-Specific Errors
1-127		Undefined

A.9.21 Command 160 (0xA0): Set Saturation Table Point

Sets a saturation table point by index.

Request Data Bytes

Byte	Format	Description
0	Unsigned-8	Index of saturation table point.
1 ~ 4	Float	Temperature degC
5 ~ 8	Float	Saturation Constant

Response Data Bytes

Byte	Format	Description
0	Unsigned-8	Index of saturation table point.
1 ~ 4	Float	Temperature degC
5 ~ 8	Float	Saturation Constant

Command-Specific Response Codes

Code	Class	Description
0	Success	No Command-Specific Errors
1-3		Undefined
4	Error	Index Out of Bounds Error.
5	Error	Too Few Data Bytes Received
6	Error	Device-Specific Command Error
7	Error	In Write Protect Mode
8-15		Undefined
16	Error	Access Restricted
8-127		Undefined

A.9.22 Command 161 (0xA1): Read Saturation Table Point

This command is to read a given temperature saturation table point.

Request Data Bytes

Byte	Format	Description
0	Unsigned-8	Index of Saturation point.

Response Data Bytes

Byte	Format	Description
0	Unsigned-8	Index of Saturation Table point.
1 ~ 4	Float	Temperature deg C
5 ~ 8	Float	Saturation Constant

Command-Specific Response Codes

Code	Class	Description
0	Success	No Command-Specific Errors
1	Error	Index Out of Bounds.
2 ~ 127		Undefined

A.9.23 Command 162 (0xA2): Set Temperature Coefficients

This command sets the temperature coefficients.

Request Data Bytes

Byte	Format	Description
0 ~ 3	Float	Calibration Temperature
4 ~ 7	Float	Temperature Dependence
8 ~ 11	Float	Dampen Factor

Response Data Bytes

Byte	Format	Description
0 ~ 3	Float	Calibration Temperature
4 ~ 7	Float	Temperature Dependence
8 ~ 11	Float	Dampen Factor

Command-Specific Response Codes

Code	Class	Description
0	Success	No Command-Specific Errors
1-4		Undefined

Code	Class	Description
5	Error	Too Few Data Bytes Received
6	Error	Device-Specific Command Error
7	Error	In Write Protect Mode
8-15		Undefined
16	Error	Access Restricted
8-127		Undefined

A.9.24 Command 163 (0xA3): Read Temperature Coefficients

This command reads the temperature coefficients.

Request Data Bytes

Byte	Format	Description
None		

Response Data Bytes

Byte	Format	Description
0 ~ 3	Float	Calibration Temperature
4 ~ 7	Float	Temperature Dependence
8 ~ 11	Float	Dampen Factor

Command-Specific Response Codes

Code	Class	Description
0	Success	No Command-Specific Errors
1-127		Undefined

A.9.25 Command 166 (0xA6): Set Saturation Table Index to Read Table Array Element

Set the Saturation table index for the reading of an array element.

Request Data Bytes

Byte	Format	Description
0	Unsigned-8	Index of array element to be read

Response Data Bytes

Byte	Format	Description
0	Unsigned-8	Index of array element to be read

Command-Specific Response Codes

Code	Class	Description
0	Success	No Command-Specific Errors
1-127		Undefined

A.9.26 Command 167 (0xA7): Read Saturation Table Index to Read Table Array Element

Read the Saturation table index for the reading of an array element.

Request Data Bytes

Byte	Format	Description
0		

Response Data Bytes

Byte	Format	Description
0	Unsigned-8	Index of array element to be read

Command-Specific Response Codes

Code	Class	Description
0	Success	No Command-Specific Errors
1-127		Undefined

A.9.27 Command 168 (0xA8): Set Hygro Calibration Curve Index to Read Table Array Element

Set the Hygro Calibration Curve index for the reading of an array element.

Request Data Bytes

Byte	Format	Description
0	Unsigned-8	Index of array element to be read

Response Data Bytes

Byte	Format	Description
0	Unsigned-8	Index of array element to be read

Command-Specific Response Codes

Code	Class	Description
0	Success	No Command-Specific Errors
1-127		Undefined

A.9.28 Command 169 (0xA9): Read Hygro Calibration Curve Table Index to Read Table Array Element

Read the Hygro Calibration index for the reading of an array element.

Request Data Bytes

Byte	Format	Description
0		

Response Data Bytes

Byte	Format	Description
0	Unsigned-8	Index of array element to be read

Command-Specific Response Codes

Code	Class	Description
0	Success	No Command-Specific Errors
1-127		Undefined

A.9.29 Command 170 (0xAA): Read Loop Measurement Type

This command is to read the loop measurement type to 1 of 3 enumerations:

0 – 4–20 mA, 1 – NAMUR, 2 – Special Zero and Span Values

When the loop measurement type is set to Special, then the Special span value and special zero value will determine the endpoint mA values instead of 4 mA and 20 mA.

Request Data Bytes

Byte	Format	Description
0		

Response Data Bytes

Byte	Format	Description
0	Unsigned-8	Loop Measurement Type
1~4	Float	Special Zero Value
5~8	Float	Special Span Value

Command-Specific Response Codes

Code	Class	Description
0	Success	No Command-Specific Errors
1-4		Undefined
5	Error	Too Few Data Bytes Received

Code	Class	Description
6	Error	Device-Specific Command Error
7	Error	In Write Protect Mode
8-15		Undefined
16	Error	Access Restricted
8-127		Undefined

A.9.30 Command 171 (0xAB): Read Output Trim Zero

This command is to trim the zero or low endpoint value to a value of 4 mA. For example, if the zero value is 4.1 mA, then the correction entered should be -0.1 mA to achieve a result of 4 mA.

Request Data Bytes

Byte	Format	Description
0		

Response Data Bytes

Byte	Format	Description
0	Unsigned-8	Enumeration. 0 = Fixed 4 mA trim, 1 = Live mA Read for live analog output or fixed 4 mA for trim purposes
1~4	Float	mA correction Value

Command-Specific Response Codes

Code	Class	Description
0	Success	No Command-Specific Errors
1-4		Undefined
5	Error	Too Few Data Bytes Received
6	Error	Device-Specific Command Error
7	Error	In Write Protect Mode
8-15		Undefined
16	Error	Access Restricted
8-127		Undefined

A.9.31 Command 171 (0xAC): Read Output Trim Span

This command is to trim the zero or low endpoint value to a value of 20 mA. For example, if the zero value is 20.1 mA, then the correction entered should be -0.1 mA to achieve a result of 20 mA.

Request Data Bytes

Byte	Format	Description
0		

Response Data Bytes

Byte	Format	Description
0	Unsigned-8	Enumeration. 0 = Fixed 20 mA trim, 1 = Live mA Read for live analog output or fixed 4 mA for trim purposes
1~4	Float	mA correction Value

Command-Specific Response Codes

Code	Class	Description
0	Success	No Command-Specific Errors
1-4		Undefined
5	Error	Too Few Data Bytes Received
6	Error	Device-Specific Command Error
7	Error	In Write Protect Mode
8-15		Undefined
16	Error	Access Restricted
8-127		Undefined

A.9.32 Command 173 (0xAD): Read Loop Current Percentage

This command is to set the output percentage of loop 1 current.

This command reads the output to a user determined percent of the 4-20 mA output.
Examples: 0 pct = 4 mA, 50% = 12 mA, and 100% = 20 mA.

Request Data Bytes

Byte	Format	Description
0		

Response Data Bytes

Byte	Format	Description
0	Unsigned-8	Enumeration. 0 = Fixed percent test, 1 = Live mA Sets live analog output or fixed mA value
1~4	Float	Loop Current Percentage, units of percent.

Command-Specific Response Codes

Code	Class	Description
0	Success	No Command-Specific Errors
1-2		Undefined
3	Error	Passed Parameter Too Large
4	Error	Passed Parameter Too Small
5	Error	Too Few Data Bytes Received

Code	Class	Description
6	Error	Device-Specific Command Error
7	Error	In Write Protect Mode
8		Undefined
9	Error	Incorrect Loop Current Mode or Value
10		Undefined
11	Error	Loop Current Not Active
12 ~ 15		Undefined
16	Error	Access Restricted
17-31		Undefined
32	Error	Busy
33 ~ 127		Undefined

A.9.33 Command 192 (0xC0): Sends password

This command will send a password to the HygroPro^{II}. If the password is right, the transmitter will allow user to operate it for 10Mins.

		Function	Password Level		
			No Password	Operator	Admin
Command					
Universal Commands	6	Write Polling Address		●	●
	17	Write Message		●	●
	18	Write Tag, Descriptor, Date		●	●
	19	Write Final Assembly Number		●	●
	22	Write Long Tag		●	●
	44	Write Primary Variable Units		●	●
Common Practice Commands	51	Write Dynamic Variable Assignments		●	●
	59	Write Number of Response Preambles		●	●

Device Specific Commands	130	Set Loop Current Zero	●	●	●
	131	Set Loop Current Gain	●	●	●
	132	Set Loop Current Percentage	●	●	●
	133	Set Primary Variable Range Values	●		●
	134	Set Loop Current Error Handling	●		●
	144	Set Loop Measurement Type	●	●	●
	145	Enter / Exit Fixed Loop 0 Current	●	●	●
	146	Set Pressure Constant	●	●	●
	147	Read Pressure Constant	●	●	●
	148	Set Temperature Constant	●	●	●
	149	Read Temperature Constant	●	●	●
	150	Set Dew Point Offset	●	●	●
	151	Read Dew Point Offset	●	●	●
	152	Set Hygro Curve Number of Points	●	●	●
	153	Read Hygro Curve Number of Points	●	●	●
	154	Set Hygro Curve Point	●	●	●
	155	Read Hygro Curve Point	●	●	●
	156	Set Pressure Curve	●	●	●
	157	Read Pressure Curve	●	●	●
	158	Set Saturation Table Number of Points	●	●	●
	159	Read Saturation Table Number of Points	●	●	●
	160	Set Saturation Table Point	●	●	●
	161	Read Saturation Table Point	●	●	●
	162	Set Temperature Coefficients	●	●	●
	163	Read Temperature Coefficients	●	●	●
	164	Send Password	●	●	●
	165	Send new Password	●		●
166	Read User Level	●	●	●	
167	Commit the Changed Parameters	●	●	●	
168	Cancel the changed Parameters	●	●	●	
202	Read User Group		●	●	
203	Set User Group	●	●	●	

Request Data Bytes

Byte	Format	Description
0	Unsigned-8	Enum User level: 0: None 2: Operator User; 3: Admin User;
1 ~ 4	Unsigned-32	User password

Response Data Bytes

Byte	Format	Description
0	Unsigned-8	User level: 0: None; 2: Operator User; 3: Admin User;

Command-Specific Response Codes

Code	Class	Description
0	Success	No Command-Specific Errors
1-4		Undefined
5	Error	Too Few Data Bytes Received
6-127		Undefined

A.9.34 Command 193 (0xC1): Sends new password

This command will send a new password to the HygroPro^{II}. If the user has the right, the transmitter changes the user password.

- General user only can change the General user password.
- Advanced user can change the General user password and Advanced user password.

Request Data Bytes

Byte	Format	Description
0	Unsigned-8	User level: 2: Operator User; 3: Admin User;
1 ~ 4	Unsigned-32	User password

Response Data Bytes

Byte	Format	Description
None		

Command-Specific Response Codes

Code	Class	Description
0	Success	No Command-Specific Errors
1-4		Undefined
5	Error	Too Few Data Bytes Received
6	Error	Device-Specific Command Error
7	Error	In Write Protect Mode
8-15		Undefined
16	Error	Access Restricted
17-127		Undefined

A.9.35 Command 194 (0xC2): Read User Level

This command will read the current user level.

Request Data Bytes

Byte	Format	Description
None		

Response Data Bytes

Byte	Format	Description
0	Unsigned-8	User Level

Command-Specific Response Codes

Code	Class	Description
0	Success	No Command-Specific Errors
1-127		Undefined

A.9.36 Command 197 (0xC5): Commit the changed parameter

This command will send commit command to the HygroPro^{II} to confirm the changed parameter. The user must send the correct password to the HygroPro^{II} and send this command in 10Mins to confirm the change.

The changed parameters will not be available after the HygroPro^{II} reboots automatically until the password is right and this command is sent to the HygroPro^{II} in 10 minutes. After the HygroPro^{II} reboots automatically, the user should resend the password to change parameter.

If this command is not sent in 10 minutes, the changed parameters will be canceled automatically.

The following table is for the commands that need to send "Commit command":

130	Set Loop Current Zero		●
131	Set Loop Current Gain		●
132	Set Loop Current Percentage		●
133	Set Primary Variable Range Values		●
134	Set Loop Current Error Handling		●
144	Set Loop 0 Measurement Type	●	●
145	Enter / Exit Fixed Loop 0 Current	●	●
146	Set Pressure Constant	●	●
147	Read Pressure Constant	●	●
148	Set Temperature Constant	●	●
149	Read Temperature Constant	●	●
150	Set Dew Point Offset	●	●
151	Read Dew Point Offset	●	●
152	Set Hygro Curve Number of Points		●
153	Read Hygro Curve Number of Points		●
154	Set Hygro Curve Point		●
155	Read Hygro Curve Point		●
156	Set Pressure Curve		●
157	Read Pressure Curve		●
158	Set Saturation Table Number of Points	●	●
159	Read Saturation Table Number of Points	●	●
160	Set Saturation Table Point	●	●
161	Read Saturation Table Point	●	●
162	Set Temperature Coefficients	●	●
163	Read Temperature Coefficients	●	●
164	Send Password	●	●
165	Send new Password		●
166	Read User Level	●	●
167	Commit the Changed Parameters	●	●
168	Cancel the changed Parameters	●	●

Request Data Bytes

Byte	Format	Description
None		

Response Data Bytes

Byte	Format	Description
None		

Command-Specific Response Codes

Code	Class	Description
0	Success	No Command-Specific Errors
1-5		Undefined
6	Error	Device-Specific Command Error
7	Error	In Write Protect Mode
8-15		Undefined
16	Error	Access Restricted
17 - 32		Undefined
33	Error	Delayed Response Initiated
34	Error	Delayed Response Running
35-127		Undefined

A.9.37 Command 198 (0xC6): Cancel the changed parameter

This command will cancel the changed parameters. And the user should resend the password to change parameter.

Request Data Bytes

Byte	Format	Description
None		

Response Data Bytes

Byte	Format	Description
None		

Command-Specific Response Codes

Code	Class	Description
0	Success	No Command-Specific Errors
1 -5		Undefined
6	Error	Device-Specific Command Error

Code	Class	Description
7	Error	In Write Protect Mode
8-15		Undefined
16	Error	Access Restricted
17-127		Undefined

A.10 Tables

A.10.1 HART Engineering Units

The unit types allowed for the Panametrics HygroPro^{II} transmitter device variables are listed below.

Unit Types			
240	Moisture	240	Dew Point Degrees C
		241	Dew Point Degrees F
		243	Parts Per Million Volume (PPMv)
		244	Parts Per Million Volume (PPBv)
		245	Parts Per Million Volume Natural Gas (PPMvNG)
		248	mg/m ³
		249	g/m ³
		246	kg/m ³
		247	LBs(MMSCFig)
		242	LBs(MMSCFng)
		240	FH
64	Temperature	32	Celsius
		33	Fahrenheit
		34	Rankine
		35	Kelvine
65	Pressure	6	Pounds per square inch (gauge)
		7	Bar
		8	Millibar
		11	Pascal
		12	Kilopascal
		13	Torr
		14	ATM
		175	Pounds per square inch (absolute)
		176	Kilograms per square meter
		237	Megapascals

A.11 Performance

A.11.1 Sampling Rates

All flow rates are updated at least once 1 time per second.

A.11.2 Power-Up

The transmitter needs at most 55 seconds to boot after it is energized. The analog output will default to 3.6mA until the PV is available.

A.11.3 Reset

The transmitter does not support Command 42 ("Device Reset") to reset itself.

A.11.4 Self-Test

The self-test procedure is executed at power up.

A.11.5 Command Response Times

Minimum	20ms
Typical	50ms
Maximum	150ms

A.11.6 Busy and Delayed-Response

The transmitter may respond with "busy" status if a further command is received while MPU testing is underway.

Delayed-response is not used.

A.11.7 Long Messages

The largest data field used is in the response to Command 183: 21 bytes including the two status bytes.

A.11.8 Non-Volatile Memory

EEPROM is used to hold the device's configuration parameters. New data is written to this memory immediately on execution of a write command.

A.11.9 Modes

When the system is in fixed current mode, it will continue measuring, it just will not update the 4-20mA output.

A.11.10 Write Protection

The transmitter has one write protect jumper. When the jumper is present, all commands are available. When the jumper is absent, neither "write" nor "command" commands are accepted.

A.11.11 Damping

Damping constant is not relevant to this meter.

A.12 Capability Checklist

Manufacturer, model and revision	Baker Hughes Panametrics HygroPro ^{II} , rev. 1
Device type	Current Output
HART revision	7.5
Device Description available	Yes

Number and type of sensors	3
Number and type of actuators	0
Number and type of host side signals	1: 4 - 20mA analog
Number of Device Variables	23
Number of Dynamic Variables	4
Mapable Dynamic Variables?	Yes
Number of common-practice commands	6
Number of device-specific commands	58
Bits of additional device status	11
Alternative operating modes?	No
Burst mode?	No
Write-protection?	Yes

A.13 Default Configuration

Parameter	Default value
Lower Range Value	Calculated based on velocity limits and pipe dimensions
Upper Range Value	Calculated based on velocity limits and pipe dimensions
PV Units	DP deg C
Sensor type	Ultrasonic
Number of wires	2
Damping time constant	0 second
Fault-indication jumper	None
Write-protect jumper	Switch default closed (i.e. write enabled)
Number of response preambles	5

A.14 Revision History

Appendix B. HygroPro^{II} Field Service Update User Manual

B.1 Setup

B.1.1 Required Tools

- Power Supply (capable of delivering 20V at 20mA)
- 5 Wire Cable with 6 Pin Female M8 connector for the HygroPro^{II}
- 2 Wire RS485 Cable with USB adapter
- Windows Laptop PC
- TeraTerm Software (open source terminal emulator)

B.1.2 Hardware Setup

1. Connect the RS485 wires to the 5 Wire Cable
 - a. Connect the RS485 Data+ (A) to the wire corresponding to Pin 2 of the M8 connector (usually White)
 - b. Connect the RS485 Data – (B) to the wire corresponding to Pin 4 of the M8 connector (Usually Black)

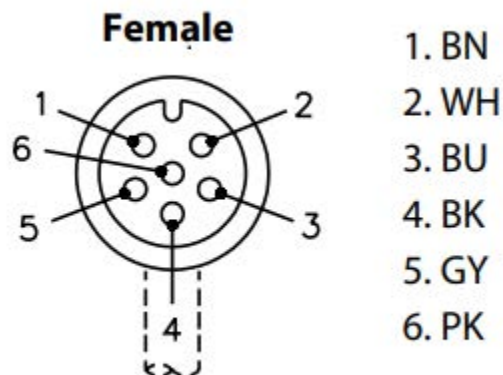

Figure 21: Pin Out for 6 Pin Female M8 Connector

2. Connect the 5 Wire cable to the power supply
 - a. With the power supply turned off
 - b. Connect the negative lead of the power supply to the wire corresponding to Pin 1 (usually Brown)
 - c. Connect the positive lead of the power supply to the wire corresponding to Pin 3 (usually Blue)
 - d. **Do not turn on** the power supply
3. Connect the 6 Pin M8 Connector to the HygroPro^{II}
4. Connect the USB plug of the RS485 adapter to your laptop
5. Set up the values for the power supply, but do not power on the device
 - a. Set the Voltage to 20 V
 - b. Set the current to 20 mA

B.1.3 Software Setup

1. Make sure the drivers for your RS485 to USB Adapter are installed
2. Start the Tera Term Application
3. The New Connection Menu will open
 - a. Select "Serial"
 - b. Select the USB to RS485 adapter from the drop-down menu (It will be labeled "USB Serial Port")

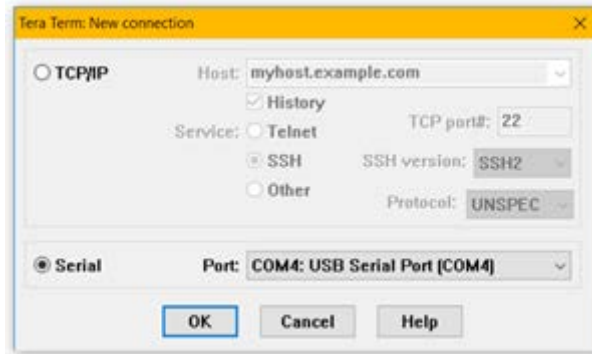

Figure 22: Select Serial Connection

4. Set the correct settings for the serial terminal
 - a. From the menu at the top of the window select "Setup" > "Serial Port..."
 - b. Set the settings as shown below
 - i. PORT: This does not need to be changed
 - ii. Baud rate: 9600
 - iii. Data: 8 bit
 - iv. Parity: none
 - v. Stop: 1 bit
 - vi. Flow Control: none
 - vii. Transmit Delay 0,0
 - c. Click "OK"

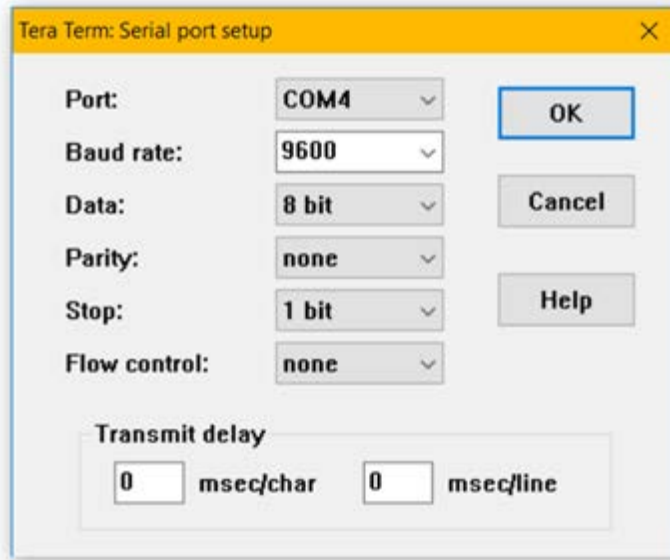

Figure 23: Serial Port Setup

5. Set the correct font and text size (Optional for readability)
 - a. From the menu at the top of the window select "Setup" > "Font..."
 - b. Set the font to "Arial"
 - c. Set the font style to "Regular"
 - d. Set the size to "12"
 - e. NOTE: These are recommended settings, you may choose whichever font you are comfortable with
 - f. Click "OK"

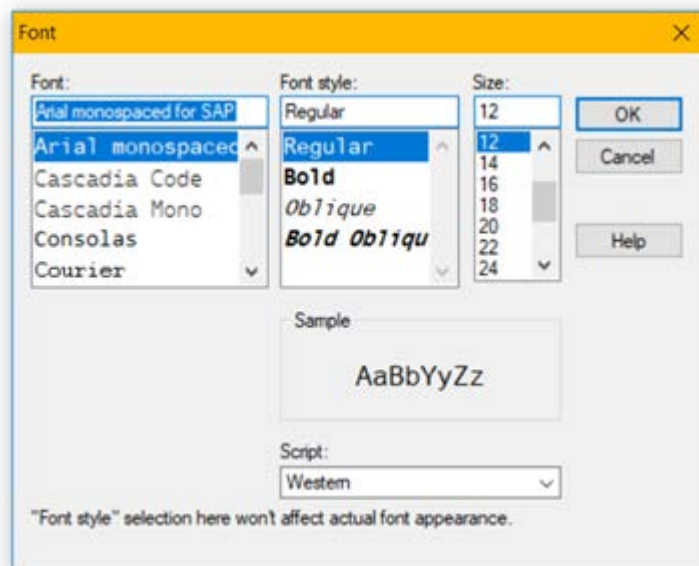

Figure 24: Optional Font Setup

B.2 Accessing the Bootloader

When the device is powered up, the HygroPro^{II} will check for a signal on the RS485 line. If it receives nothing it will jump past the Bootloader and run the normal Instrument Program.

B.2.1 Activating the Bootloader

To activate the bootloader, we will send a signal while the device is powering up.

1. Click into the Tera Term window
2. Press and hold the “y” key on your keyboard
3. While keeping the “y” key held down, turn on the power to the HygroPro^{II}
4. Continue to hold the “y” key down for approximately 3 seconds
5. Release the “y” key
6. The Tera Term window will show the Password Menu

B.2.2 Entering the Password

The password for the HygroPro^{II} Bootloader is generated using the unique Device ID Number. The Bootloader password is separate from the Service passcode. This Device ID number is independent from the device Serial Number.

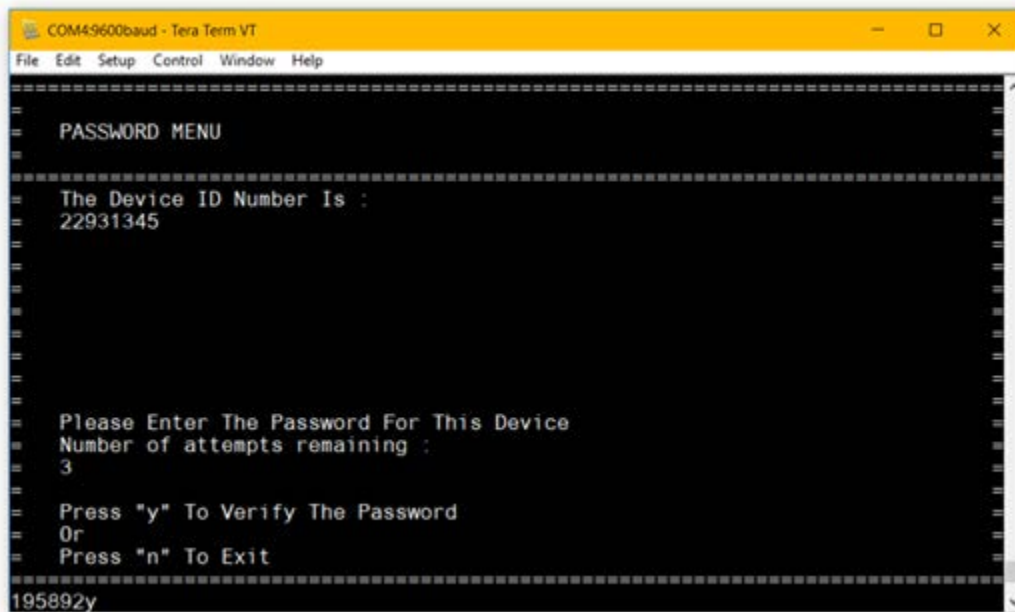

Figure 25: Password Menu

B.2.2.1 To enter the password

1. Record the Device ID Number shown in the Tera Term window
2. Contact Panametrics Tech Support with details of the Device ID Number for your HygroPro^{II} to receive your device's password

B.2.2.2 To enter the password

1. Enter the password into the Tera Term window by typing each number
2. When you have typed all 6 digits press “y” to check the password
3. If the password is correct Tera Term will bring you to the Main Menu of the Bootloader
 - NOTE: If you type the password incorrectly there is no way to change it, instead press “y” to attempt to verify the password. This will count as a failed attempt, but the device will allow you to retry entering the password two more times.

B.2.2.3 Incorrect Passwords

You will have 3 attempts to enter the correct passcode. If you failed to enter the passcode 3 times in a row, then the device will lock you out for an amount of time. After this time out has finished the device will allow you 3 more attempts to enter the passcode.

B.2.2.4 Exiting without inputting a passcode

1. To exit the Bootloader press "n"
2. The Instrument Program will now run

B.3 Using the Bootloader

B.3.1 The Main Menu

The Main Menu is where you can access all the features of the bootloader.

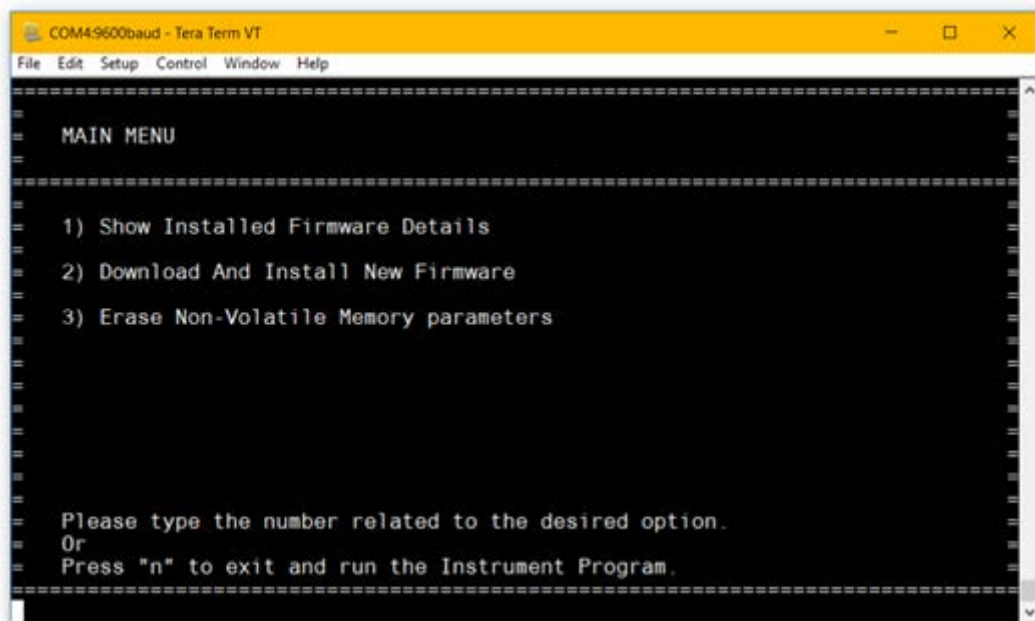

Figure 26: Main Menu

B.3.1.1 Accessing the sub menus

1. To access the sub menu, type the number shown beside that option in the Main Menu
2. The bootloader will show the selected menu

B.3.1.2 Exiting the bootloader

1. Press "n" to exit the bootloader
2. The instrument program will now run

B.3.1.3 Menu timeouts

All menus in the bootloader are set to time out after 5 minutes of inactivity. If you wish to keep in the same menu without it timing out, then type any letter or number. The bootloader will warn you if that was not a valid option, and this will reset the timeout.

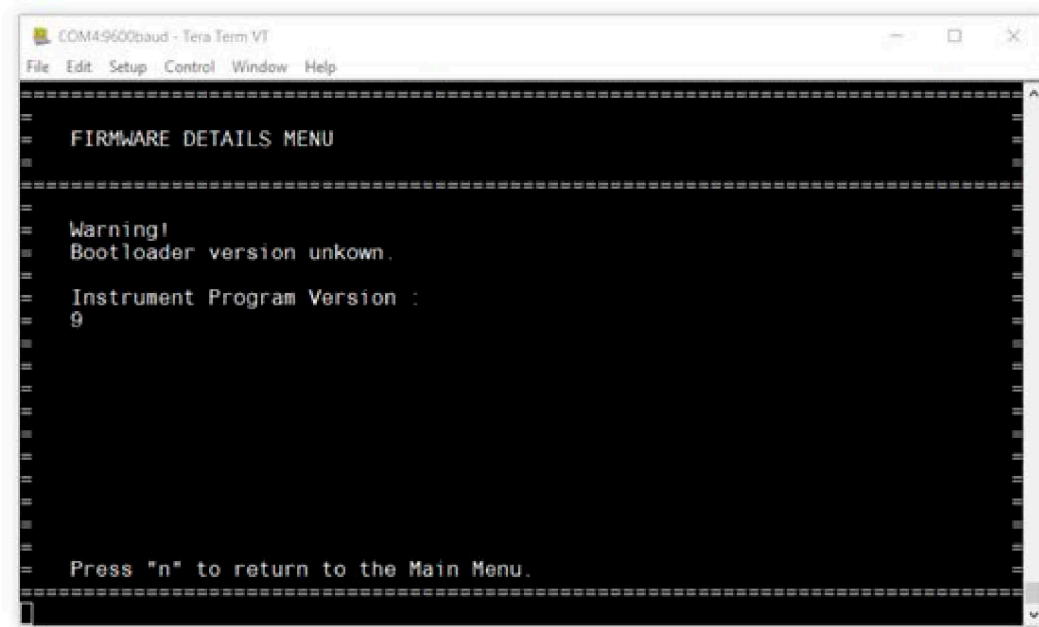

Figure 28: Firmware Details with Warning

B.3.2.2 To return to the Main Menu

1. Press "n" to exit the Firmware Details Menu and return to the Main Menu

B.3.3 Download and Install New Firmware Menu

This is where you can download and install both new bootloader and instrument program firmware. The device will require a signed firmware binary, ending in ".bin".

B.3.3.1 Download and install new firmware

1. From the Main Menu press "2" to open the Download and Install New Firmware Menu
2. The menu below will be shown

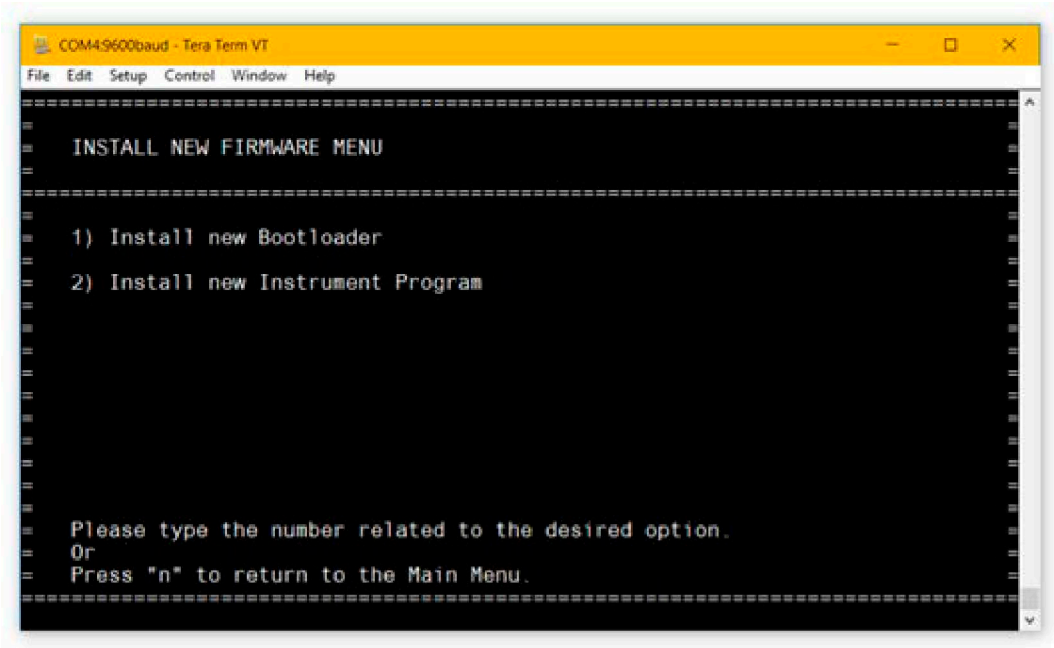

Figure 29: Install New Firmware Menu

3. Select which firmware you would like to install
 - a. Press "1" to install new bootloader firmware
 - b. Press "2" to install new Instrument program firmware
4. The menu below will be shown
 - a. **NOTE: IMPORTANT:** It is important that the device does not lose power from this point until the firmware installation is confirmed. If the device loses power during the installation procedure it may cause a permanent software failure of the device.

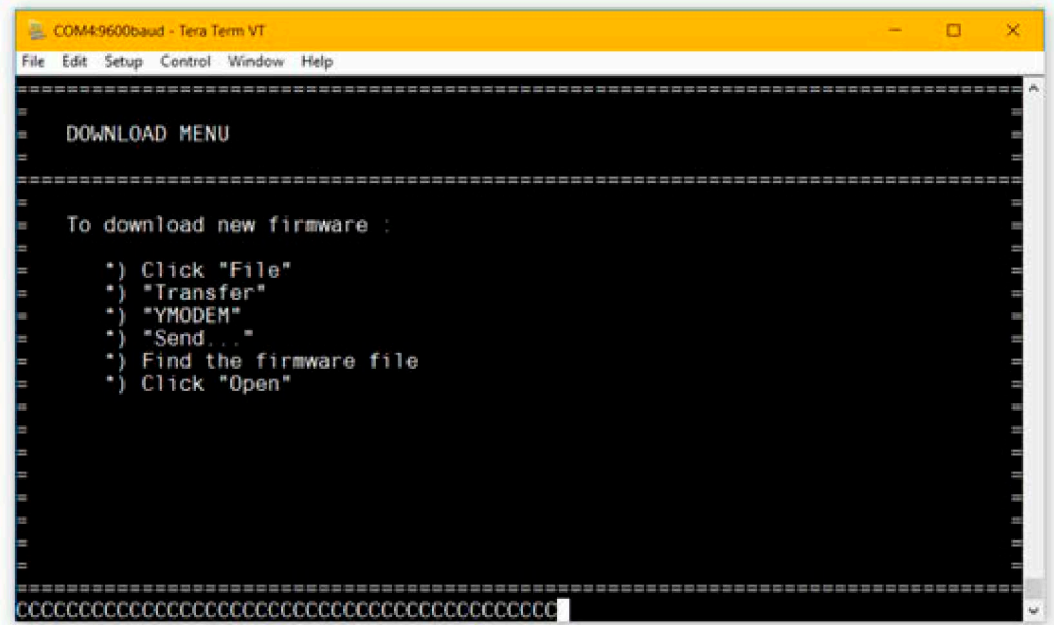

Figure 30: Download Menu

5. From the menu at the top of the window click "File" > "Transfer" > "YMODEM" > "Send..."
 - a. NOTE: If you wish to exit this menu you must press "a" twice in a row (This is a special command required to interrupt the file transfer)

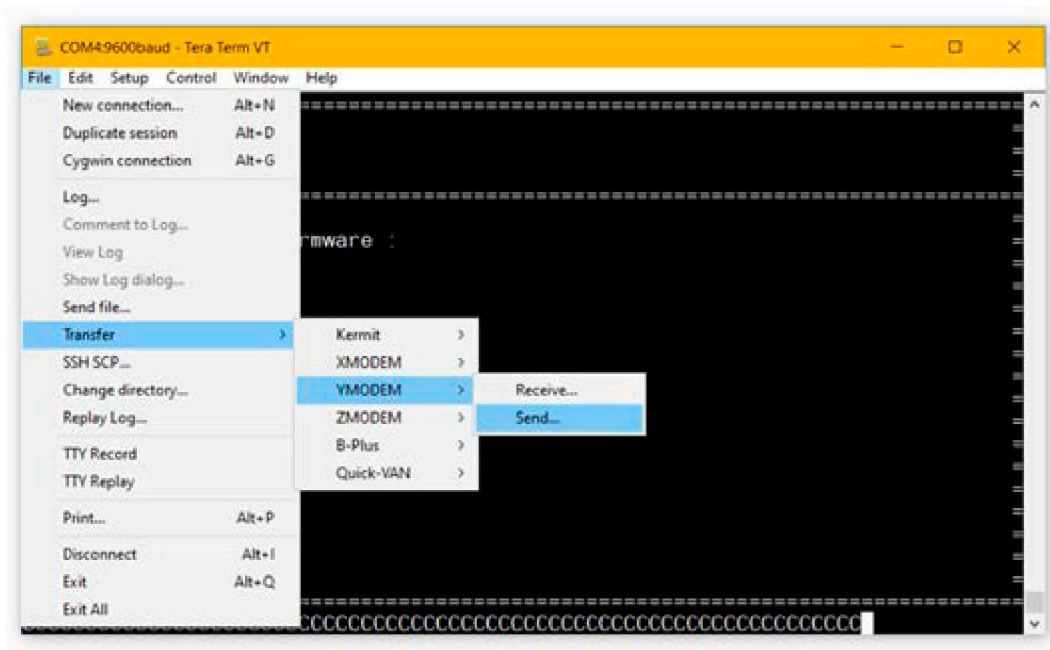

Figure 31: Firmware Download Menu

6. A file browser window will open
7. Find your firmware binary file ".bin" and select it
8. Click "Open"
9. A pop-up window shown below will open

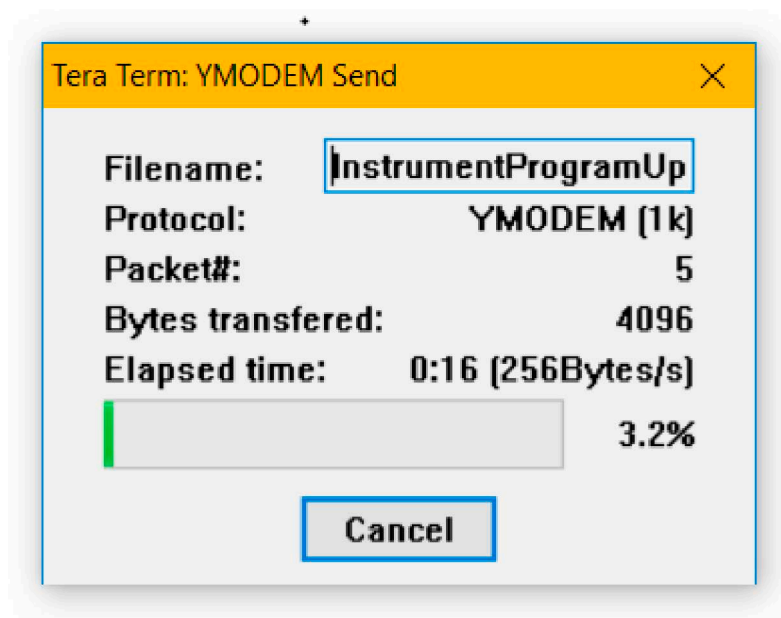

Figure 32: YMODEM Download

14. If new instrument program firmware was installed the bootloader will return to the main menu
15. If new bootloader firmware was downloaded, then the device will automatically restart and run the new bootloader
 - a. NOTE: You will have to enter the password again

B.3.4 Erase NVM Menu

The Erase Non-Volatile Memory Menu is used to erase any settings or calibration data stored in the flash memory of the device. For the HygroPro^{II} Probe this includes all calibrations, calibration date and serial numbers. For the HygroPro^{II} Display this includes all 4-20mA output settings, display settings and serial numbers.

B.3.4.1 To erase non-volatile memory

1. From the Main Menu press "3" to open the Erase NVM Menu
2. Press "y" to confirm
3. The device will attempt to erase and show a status message
4. IF the device is successful it will return to the Main Menu
 - a. If the device is unsuccessful it will return to the Erase NVM Menu
 - b. You may press "y" to attempt the erase again

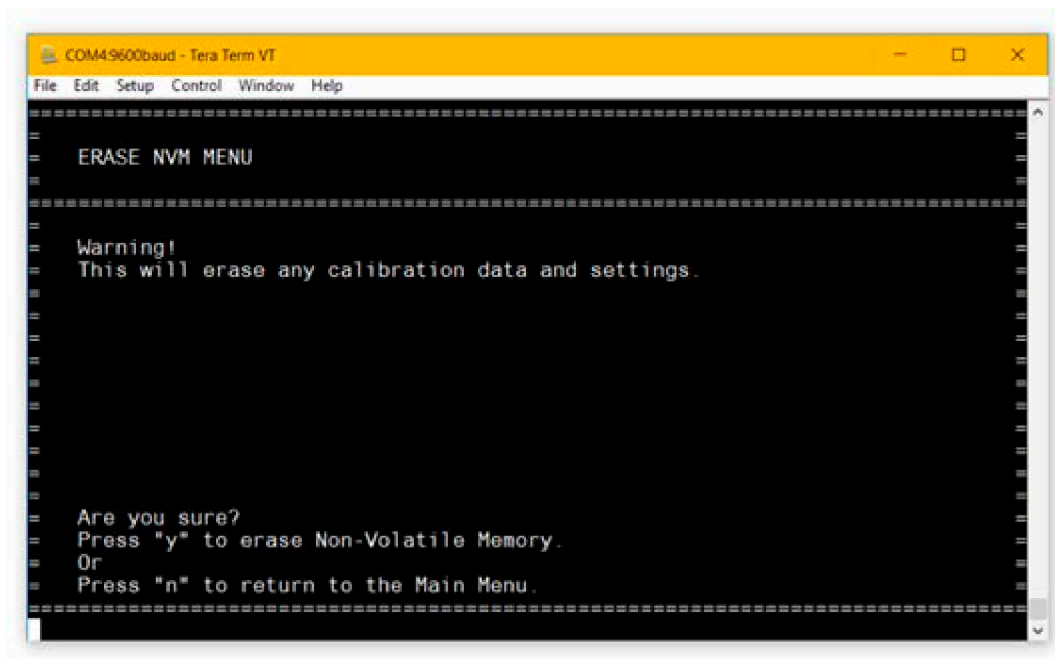

Figure 35: Erase Non-Volatile Memory Menu

[no content intended for this page]

Warranty

Each instrument manufactured by Panametrics, a Baker Hughes company is warranted to be free from defects in material and workmanship. Liability under this warranty is limited to restoring the instrument to normal operation or replacing the instrument, at the sole discretion of Panametrics. Fuses and batteries are specifically excluded from any liability. This warranty is effective from the date of delivery to the original purchaser. If Panametrics determines that the equipment was defective, the warranty period is:

- One year from delivery for electronic or mechanical failures.
- One year from delivery for sensor shelf life.

If Panametrics determines that the equipment was damaged by misuse, improper installation, the use of unauthorized replacement parts, or operating conditions outside the guidelines specified by Panametrics, the repairs are not covered under this warranty.

The warranties set forth herein are exclusive and are in lieu of all other warranties whether statutory, express or implied (including warranties or merchantability and fitness for a particular purpose, and warranties arising from course of dealing or usage or trade).

Return Policy

If a Panametrics instrument malfunctions within the warranty period, the following procedure must be completed:

1. Notify Panametrics, giving full details of the problem, and provide the model number and serial number of the instrument. If the nature of the problem indicates the need for factory service, Panametrics will issue a RETURN MATERIAL AUTHORIZATION (RMA), and shipping instructions for the return of the instrument to a service center will be provided.
2. If Panametrics instructs you to send your instrument to a service center, it must be shipped prepaid to the authorized repair station indicated in the shipping instructions.
3. Upon receipt, Panametrics will evaluate the instrument to determine the cause of the malfunction.

Then, one of the following courses of action will then be taken:

- If the damage is covered under the terms of the warranty, the instrument will be repaired at no cost to the owner and returned.
- If Panametrics determines that the damage is not covered under the terms of the warranty, or if the warranty has expired, an estimate for the cost of the repairs at standard rates will be provided. Upon receipt of the owner's approval to proceed, the instrument will be repaired and returned.

[no content intended for this page]



Scan here or use the link below for
Customer Service, Technical Support,
or Service Information:
<https://panametrics.com/support>

Technical Support email:
panametricstechsupport@bakerhughes.com

Copyright 2024 Baker Hughes company.

This material contains one or more registered
trademarks of Baker Hughes Company and its
subsidiaries in one or more countries. All third-party
product and company names are trademarks of their
respective holders.

BH072C11 EN C (05/2024)

Baker Hughes 