



## Operation and Maintenance Manual

---

### 40 Ton Hydraulic Pin Puller Kit Model PPH40

Document Number: L4761

Document Revision: A

Issue Date: 29-NOV-2023

Language: English  EN



To reduce the risk of injury, user must read and understand this document before use.

# ABOUT US

Enerpac is a global market leader in high pressure hydraulic tools, controlled force products, portable machining, on-site services and solutions for precise positioning of heavy loads. As a leading innovator with over a 100-year legacy, Enerpac has helped move and maintain some of the largest structures on earth. When safety and precision matters, elite professionals in industries such as aerospace, infrastructure, manufacturing, mining, oil & gas and power generation rely on Enerpac for quality tools, services and solutions. For additional information, visit [www.enerpac.com](http://www.enerpac.com).

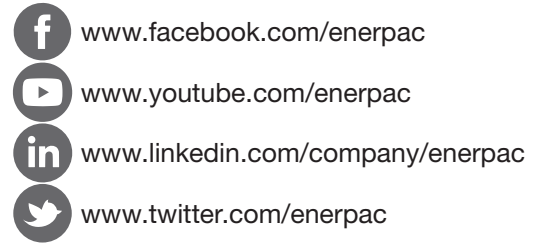

# WARRANTY

Refer to the Enerpac Global Warranty document for terms and conditions of the product warranty. Such warranty information can be found at [www.enerpac.com](http://www.enerpac.com).

# NAMEPLATE

Refer to the product nameplate (located on the hydraulic cylinder) for model number, serial number, weights and other applicable information.

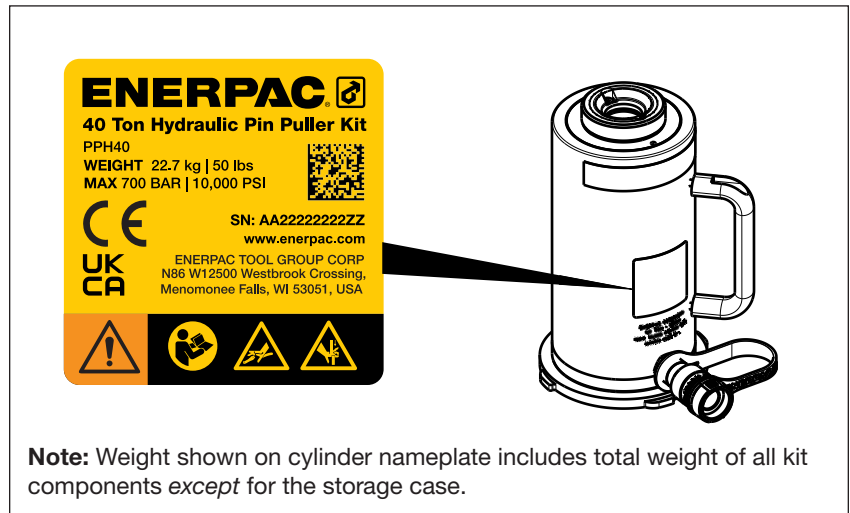

# AVAILABLE LANGUAGES

An electronic copy of this document is available online in multiple languages:

- EN English - For other languages, visit [www.enerpac.com](http://www.enerpac.com).
- CS Čeština - Další jazyky naleznete na adrese [www.enerpac.com](http://www.enerpac.com).
- DE Deutsch - Weitere Sprachen finden Sie unter [www.enerpac.com](http://www.enerpac.com).
- ES Español - Para otros idiomas visite [www.enerpac.com](http://www.enerpac.com).
- FI Suomi - Muita kieliä on osoitteessa [www.enerpac.com](http://www.enerpac.com).
- FR Français - Pour toutes les autres langues, rendez-vous sur [www.enerpac.com](http://www.enerpac.com).
- IT Italiano - Per altre lingue visitate il sito [www.enerpac.com.x](http://www.enerpac.com.x)
- JA 日本語 - その他の言語は [www.enerpac.com](http://www.enerpac.com) でご覧いただけます。
- KO 한국어 - 이 지침 시트의 다른 언어 버전은 [www.enerpac.com](http://www.enerpac.com).
- NL Nederlands - Ga voor de overige talen naar [www.enerpac.com](http://www.enerpac.com).
- PL Polski - Inne wersje językowe można znaleźć na stronie [www.enerpac.com](http://www.enerpac.com).
- PT Português - Para outros idiomas consulte [www.enerpac.com](http://www.enerpac.com).
- SV Svenska - För andra språk, besök [www.enerpac.com](http://www.enerpac.com).
- ZH 中文 - 如需其他语言, 请前往 [www.enerpac.com](http://www.enerpac.com).

# CONTENTS

PAGE

1.0 SAFETY..... 4

2.0 COMPLIANCE ..... 6

3.0 PRODUCT DATA..... 7

4.0 FEATURES AND COMPONENTS ..... 10

5.0 DESCRIPTION..... 11

6.0 SETUP..... 11

7.0 INSTALLATION ..... 13

8.0 OPERATION..... 15

9.0 CLEANING AND MAINTENANCE ..... 16

10.0 STORAGE ..... 17

11.0 RELIEVING TRAPPED PRESSURE IN CYLINDER..... 17

12.0 SAFE DISPOSAL PROCEDURE ..... 17

13.0 TROUBLESHOOTING ..... 18

14.0 REPAIR PARTS SECTION..... 22

# 1.0 SAFETY

Read all instructions carefully. Follow all recommended safety precautions to avoid personal injury as well as damage to the product and / or damage to other property. Enerpac cannot be responsible for any damage or injury from unsafe use, lack of maintenance, or incorrect operation. Do not remove warning labels, tags, or decals. In the event that any questions or concerns arise, contact Enerpac or a local Enerpac distributor for clarification.

## Save these instructions for future use.

Appropriate training in the safe use of high pressure, high force hydraulic tools is required prior to the operation of the pin puller. If training is needed, contact your local Enerpac distributor or authorized service center for information about a Enerpac hydraulic safety training course.

This manual follows a system of safety alert symbols, signals, words, and safety messages to warn the user of specific hazards. Failure to comply with these warnings could result in death or serious personal injury, as well as damage to the equipment or other property.



The Safety Alert Symbol appears throughout this manual. It is used to alert you to potential physical injury hazards. Pay close attention to Safety Alert Symbols and obey all safety messages that follow this symbol to avoid the possibility of death or serious injury.

Safety Alert Symbols are used in conjunction with certain Signal Words that call attention to safety messages or property damage messages and designate a degree or level of hazard seriousness. The Signal Words used in this manual are DANGER, WARNING, CAUTION and NOTICE.

**⚠ DANGER** Indicates a hazardous situation that, if not avoided, will result in death or serious personal injury.

**⚠ WARNING** Indicates a hazardous situation that, if not avoided, could result in death or serious personal injury.

**⚠ CAUTION** Indicates a hazardous situation that, if not avoided, could result in minor or moderate personal injury.

**NOTICE** Indicates information considered important, but not hazard related (e.g. messages related to property damage). Please note that the Safety Alert Symbol will not be used with the signal word.

## 1.1 Hydraulic Safety Precautions



Failure to observe and comply with the following precautions could result in death or serious personal injury. Property damage could also occur.

### 1.1.1 General Hydraulic Safety Precautions

- Never set a pressure relief valve to a higher pressure than the maximum rated working pressure of the pump.

- Never remove, modify, disable or readjust the pump's internal safety relief valve.
- Do not handle pressurized hydraulic hoses. Escaping oil under pressure can penetrate the skin. If oil is injected under the skin, see a doctor immediately.
- Do not exceed the hydraulic cylinder's maximum working pressure rating of 10,000 psi [700 bar]. Overloading may cause equipment failure and possible personal injury.
- The system operating pressure must not exceed the pressure rating of the lowest rated component in the system. All hoses, fittings, couplers and accessories used with the pin puller must be rated at 10,000 psi [700 bar] minimum.
- Do not pressurize uncoupled hydraulic couplers. Never use a cylinder or tool with uncoupled couplers. If the cylinder or tool becomes extremely overloaded, components can fail catastrophically.
- Never use a hydraulic cylinder or tool as a shim or spacer in any application.
- Install a pressure gauge (user-supplied) in the system to monitor operating pressure. It is your window to see what is happening in the system.
- Wear personal protective equipment (P.P.E.) when operating hydraulic equipment.
- Always wear eye protection. Safety equipment such as dust mask, non-skid safety shoes, hard hat, or hearing protection used for appropriate conditions will reduce personal injuries.
- Immediately replace worn or damaged parts with genuine Enerpac parts. Enerpac parts are designed to fit properly and to withstand high loads. Non-Enerpac parts may break or cause the pin puller to malfunction. Personal injury and property damage may also occur.



Failure to observe and comply with the following precautions could result in minor or moderate personal injury. Property damage could also occur.

- Do not use or repair damaged hydraulic hoses. Avoid sharp bends and kinks when routing hydraulic hoses. Using a bent or kinked hose will cause severe back-pressure. Sharp bends and kinks will internally damage the hose, leading to premature hose failure.
- Do not drop heavy objects on hydraulic hoses. A sharp impact may cause internal damage to hose wire strands. Applying pressure to a damaged hose may cause it to rupture.
- Do not lift hydraulic equipment by the hoses or swivel couplers. Use the carrying handle or strap on the equipment.
- Keep hydraulic equipment away from flames and heat. Excessive heat will soften packings and seals, resulting in fluid leaks. Heat also weakens hose materials and packings.
- Protect all hydraulic equipment from weld spatter.

**NOTICE** Hydraulic equipment must only be serviced by a qualified hydraulic technician. For repair service, contact an Enerpac authorized service center in your area.

### 1.1.2 Pin Puller Safety Precautions

**WARNING**

Failure to observe and comply with the following precautions could result in death or serious personal injury. Property damage could also occur.

- Read and completely understand the safety precautions and instructions in this manual before operating the tensioners or preparing them for use. Always follow all safety precautions and instructions, including those that are contained within the procedures of this manual.
- Always support the pin puller with a hoist and sling, chains or other suitable lifting apparatus. **Puller assembly will drop immediately if it is not supported when pin is removed.**
- Stay clear of the pin puller while it is in operation. Do not allow persons to be under or close beside the pin puller while it is being used. Stay clear of the line of fire area (refer to Section 1.1.3).
- To avoid personal injury, keep hands and feet away from pinch point areas.
- Before beginning a pulling procedure, be sure that the faceplate of the leading column section is flush with the mating surface of the machinery and perpendicular to the pin being pulled.
- Be sure threaded steel rod (user supplied) is of the proper specifications as specified in Section 6.5 of this manual.

- Be sure quick nut is the proper thread size for the threaded steel rod (user-supplied) being used.
- Do not exceed equipment ratings. Never attempt to apply more force than the pin puller tool is rated for. Overloading may cause equipment failure and possible personal injury.
- Allow only trained and authorized personnel to use the pin puller.
- Do not re-engineer or modify any pin puller components.
- Do not weld or otherwise modify the cylinder to attach a base or other support.
- Refer to Section 8.1 of this manual for additional safety precautions.

### 1.1.3 Pin Puller Safety Hazards

Refer to Figure 1:

- Stay clear of the *line of fire* area (located at the cylinder plunger end) while the puller is in operation and whenever any pressure is present in the hydraulic system. If the threaded rod and/or quick nut should fail, these loose or broken parts will become projectiles and strike persons working in their path. Serious personal injury or death will result.
- Stay clear of area under and beside the pin puller while a pulling procedure is in progress. Pin Puller assembly could drop or swing if component failure occurs or if the assembly is not properly supported by the lifting device as the pin is being removed.
- Pin and threaded rod will loosen when pin is fully removed. These items may drop suddenly or may be retained, depending on the location of the opening in the column sections.

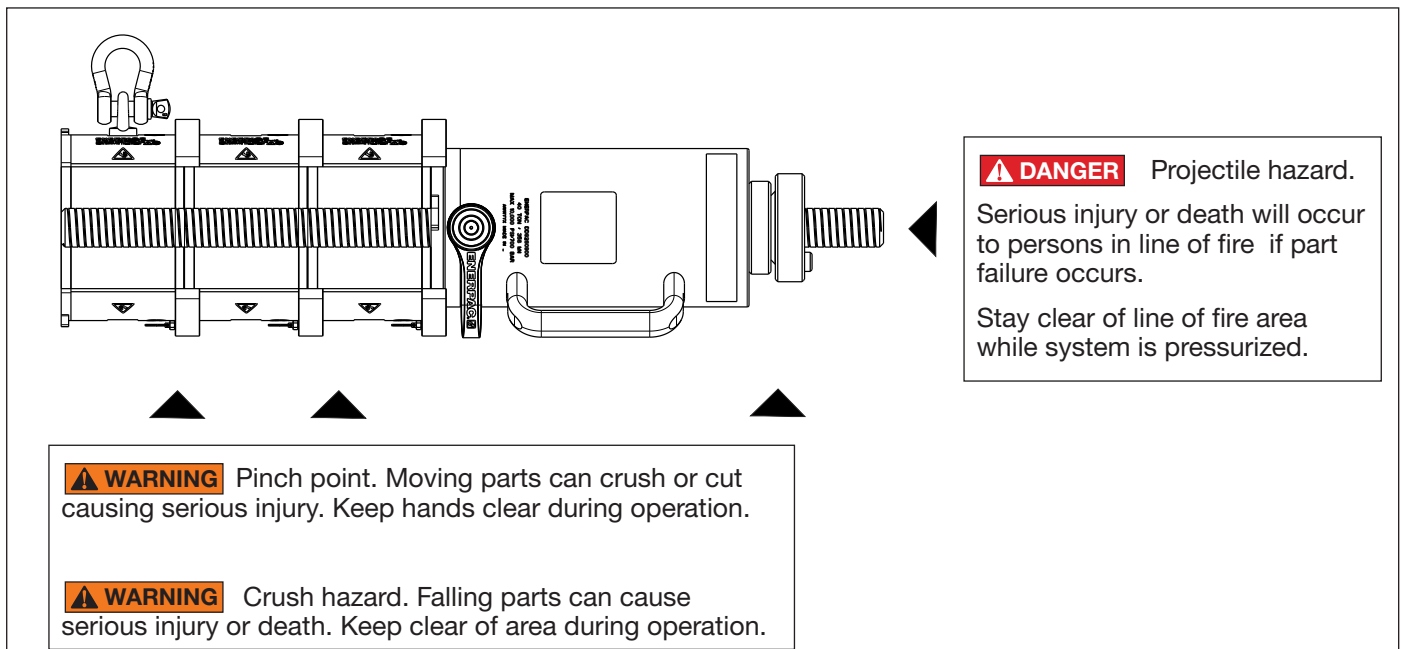







Figure 1: Pin Puller Safety Hazards

## 1.2 Symbols

Various pictorial symbols are affixed to the pin puller's hydraulic cylinder. Additional pictorial symbols are located on the pin puller column sections and quick nuts.

In some instances, these symbols may advise the user of potentially hazardous situations. Other symbols may be informational only. Understand the meaning of each symbol before using the pin puller.

Selected symbols are shown in the following chart:

Symbol	Definition
	Safety Alert Triangle (general hazard warning)
	Read instruction manual. Save instructions for future use.
	Hydraulic Injection Hazard
	Pinch Point/Crush Hazard.
	Lifting Point.
	Approved or recommended for use.

## 1.3 Labels

Make sure all labels and decals are legible and securely affixed to the pin puller components. If worn or missing, obtain replacements from Enerpac.

### 1.4 State of California Proposition 65 Warning

 **WARNING!** This product can expose you to chemicals including ethylbenzene, which is known to the State of California to cause cancer, and toluene, which is known to the State of California to cause birth defects or other reproductive harm.

For more information, go to [www.P65Warnings.ca.gov](http://www.P65Warnings.ca.gov).

## 2.0 COMPLIANCE

### 2.1 Compliance Statements

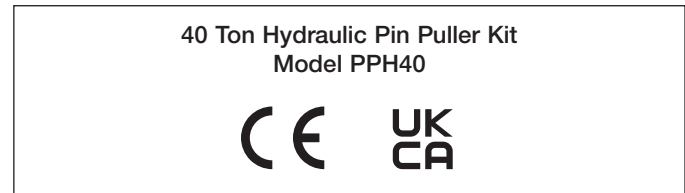

Enerpac declares that the model PPH40 40 Ton Hydraulic Pin Puller Kit has been tested and conforms to applicable standards and is approved to carry the CE and UKCA certification marks.

**NOTICE** A copy of the product's EU Declaration of Conformity is enclosed with each shipment. A copy of the UK Self-Declaration of Conformity is also enclosed.

# 3.0 PRODUCT DATA

## 3.1 Hydraulic Cylinder Specifications

Model	Type	Plunger	Pulling Capacity		Stroke		Max Hyd. Pressure		Oil Capacity (extended)		Weight		Hydraulic Connection*
			ton	kN	in	mm	psi	bar	in <sup>3</sup>	cm <sup>3</sup>	lb	kg	
DD9260900	Single-acting, spring return	Hollow	40	356	3.94	100	10,000	700	31.18	511	22.1	10.0	Enerpac CR400

\* Enerpac CR400 female coupler is pre-installed. Cylinder pressure port is 3/8" NPTF.

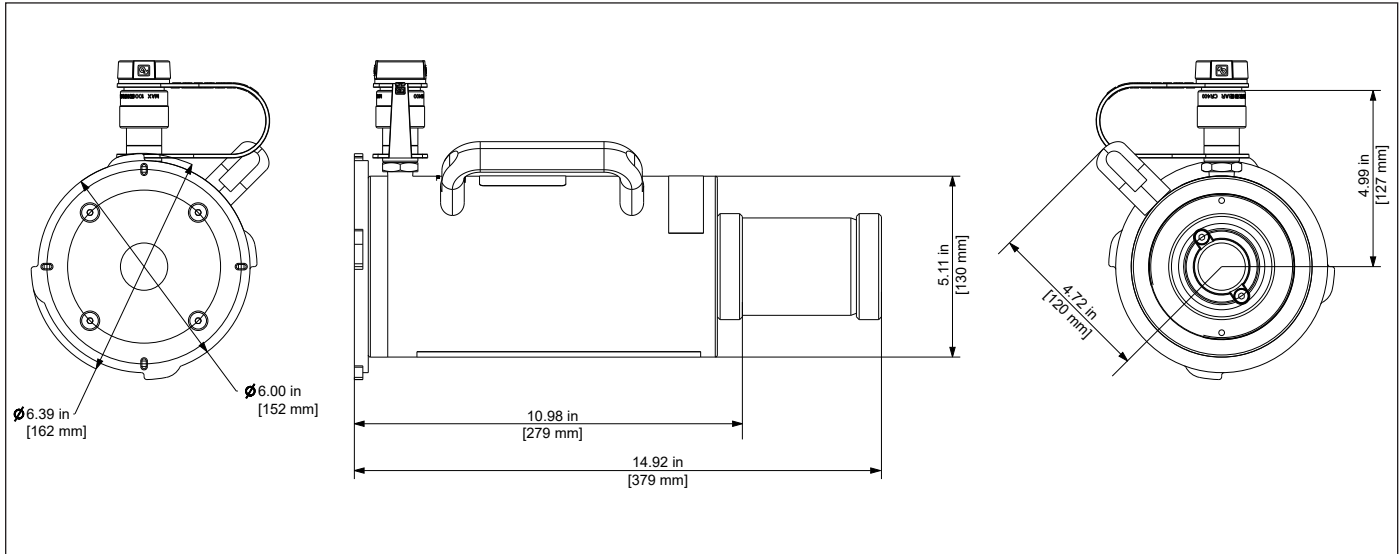

## 3.2 Column Section Specifications

Model	Weight (each)	
	lb	kg
PPH40C	8.3	3.8

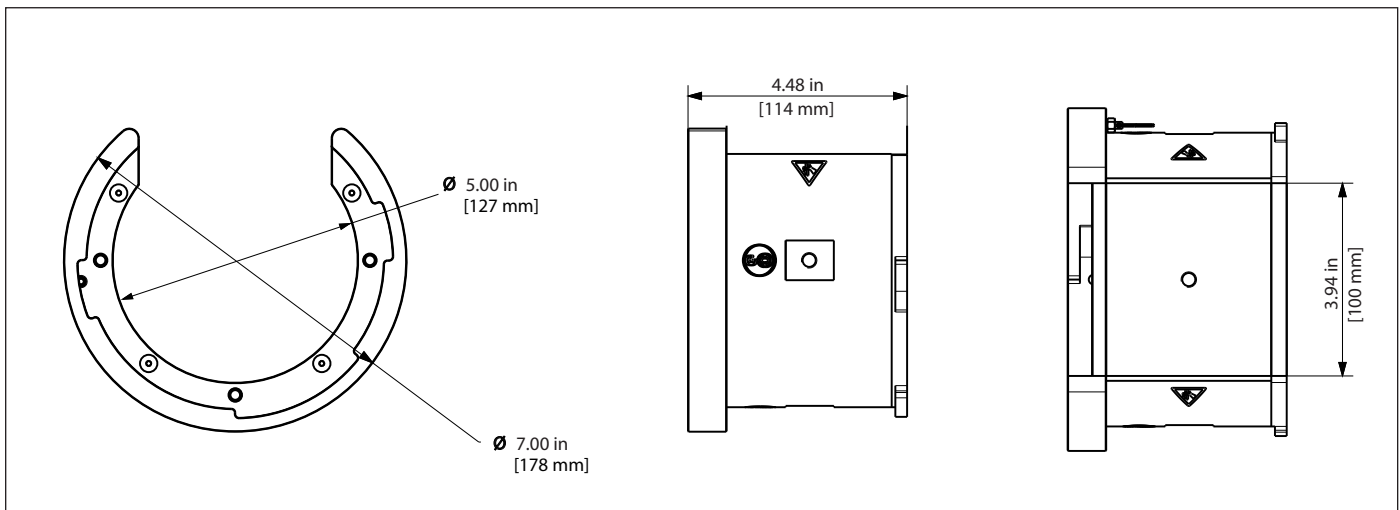

### 3.3 Quick Nuts

Model	Internal Thread Size	Weight (each)	
		lb	kg
PPH40Q100U14	1" - 14 UNS	2.5	1.1
PPH40Q125U12	1-1/4" - 12 UNF	2.5	1.1
PPH40QM30x35	M30 x 3.5	2.5	1.1

NOTE: Quick nut PPH40Q125U12 is included in the PPH40 kit. Quick nuts PPH40Q100U14 and PPH40QM30X35 are available as optional accessories.

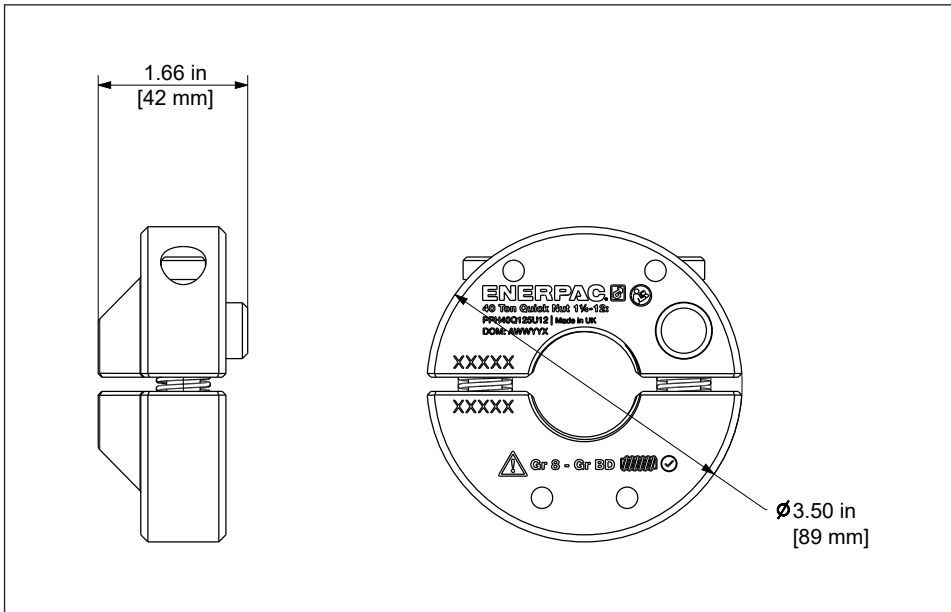

### 3.4 Storage Case

Model	Weight of Storage Case with PPH40 Kit Components*		Weight of Empty Storage Case	
	lb	kg	lb	kg
DD9328530	70.0	31.8	20.3	9.2

\* Includes total weight of all kit components, including storage case, hydraulic cylinder, three column sections, one quick nut, eyebolt and shackle.

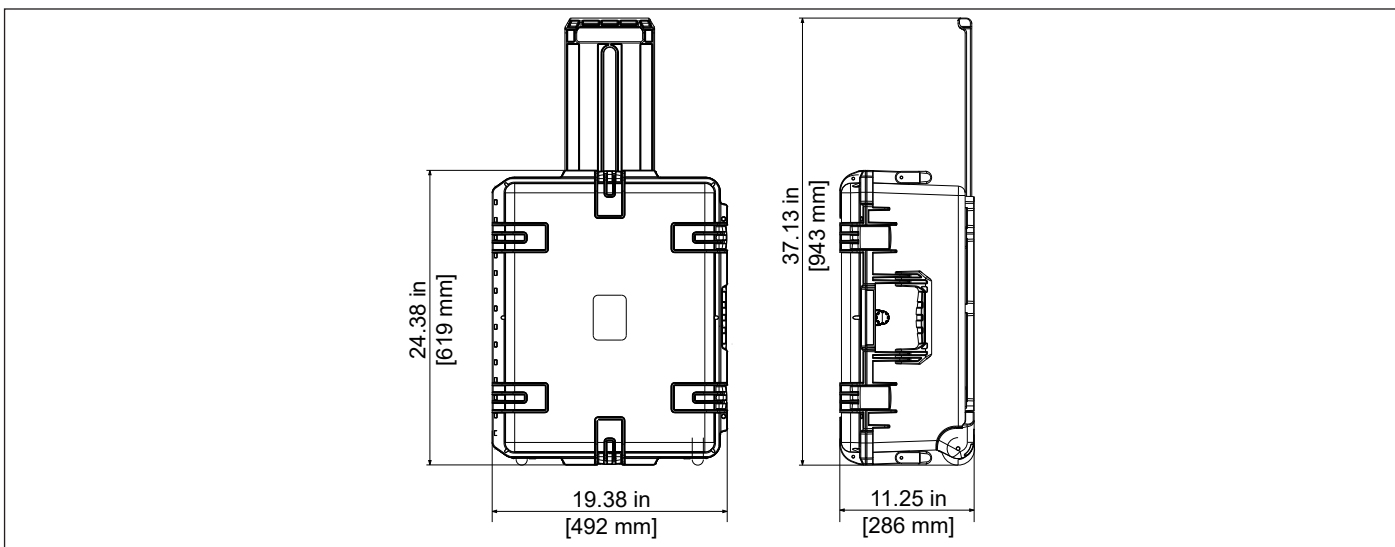



### 3.5 External Dimensions (puller assembled & mounted)

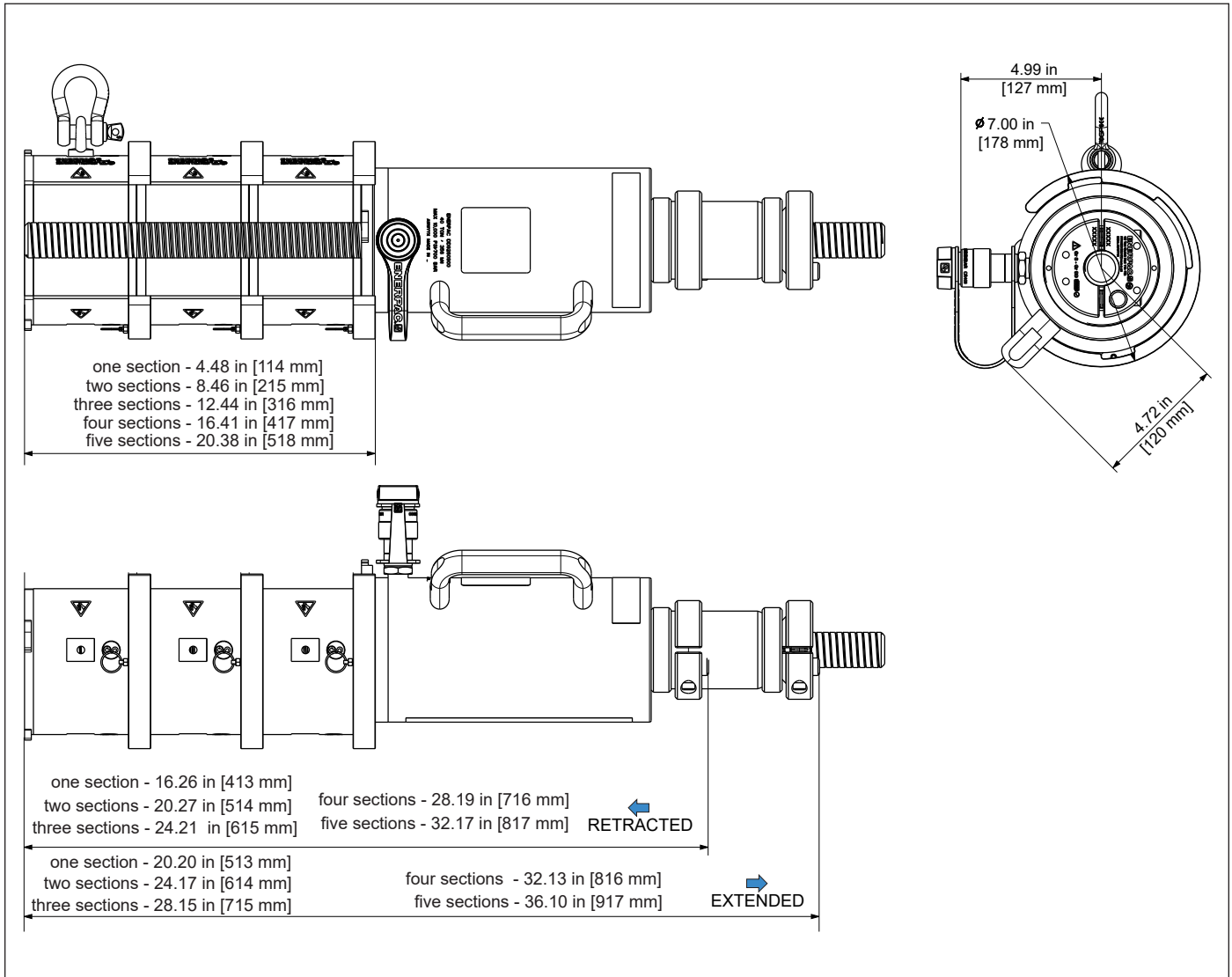

### 3.6 Additional Data

Model	Quantity of Column Sections		Maximum Length of Joint Pin to be Removed:									
	Included with Puller	Maximum Allowed	Using 1 Section		Using 2 Sections		Using 3 Sections		Using 4 Sections		Using 5 Sections	
			in	mm	in	mm	in	mm	in	mm	in	mm
PPH40	3	5	3.97	101	7.95	202	11.92	303	15.90	404	19.88	505

NOTE: Three column sections are included with each pin puller kit. Additional column sections are available as an optional accessory. A maximum of five column sections can be installed.

Model	Approximate Total Weight of Assembled Cylinder, Column Sections and Quick Nut:									
	Using 1 Section		Using 2 Sections		Using 3 Sections		Using 4 Sections		Using 5 Sections	
	lb	kg	lb	kg	lb	kg	lb	kg	lb	kg
PPH40	32.9	14.9	41.2	18.7	49.5	22.5	57.8	26.3	66.1	30.0

NOTE: Weights of threaded rod and joint pin are not included.

**NOTICE**

5 column sections is the maximum allowed. Do not use more than 5 column sections.

# 4.0 FEATURES AND COMPONENTS

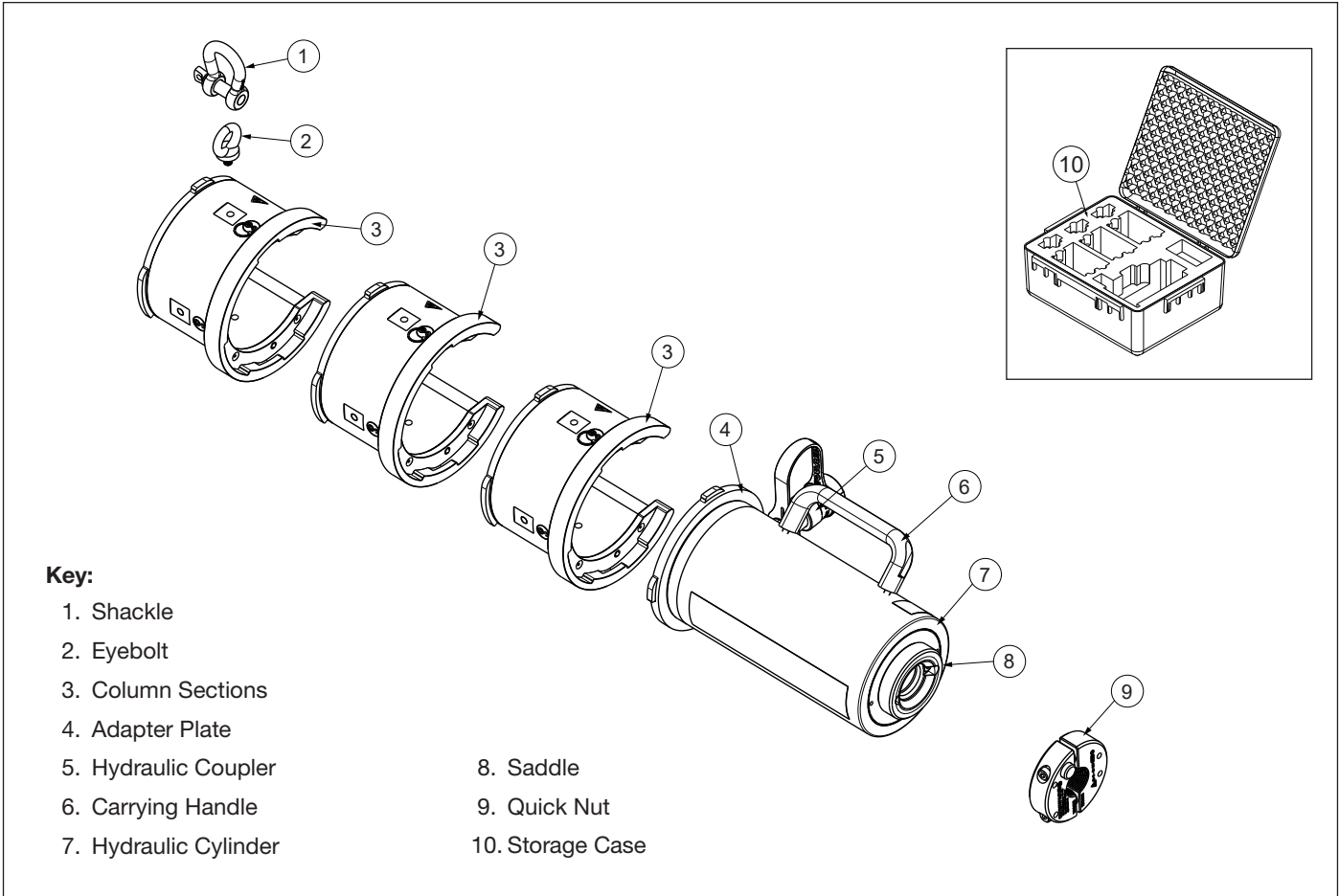

Figure 2: Features & Components, PPH40 Hydraulic Pin Puller Kit

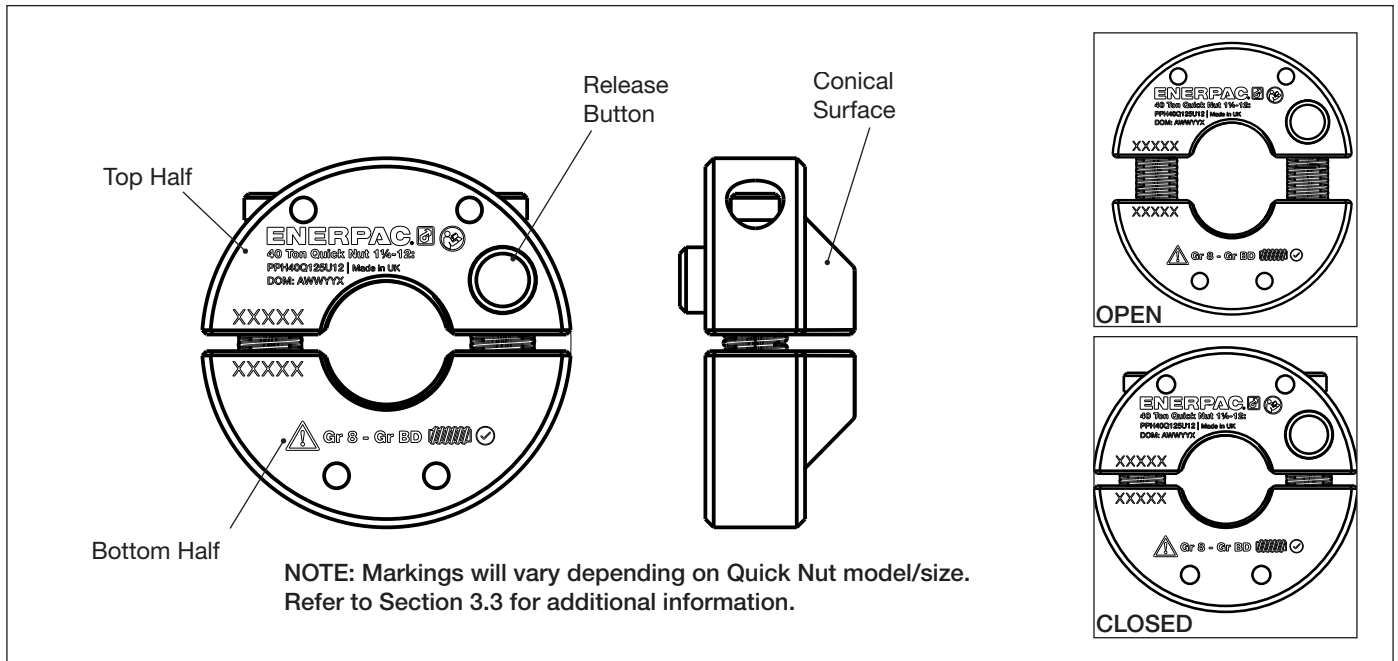

Figure 3: Quick Nut Details

## 5.0 DESCRIPTION

The Enerpac Model PPH40 Hydraulic Pin Puller Kit allows quick and safe removal of joint pins used in heavy machinery, construction equipment and other similar applications.

The kit consists of a specially designed aluminium body hydraulic cylinder, three C-shaped steel column sections, and a quick nut fastener. An eyebolt and shackle are also provided to safely support the assembled device while in use.

The assembled unit is typically mounted horizontally, on either the left or right hand end of the pin to be removed. However, vertical mounting above or below a vertically oriented pin is also permitted.

Hydraulic power can be supplied by any compatible 10,000 psi [700 bar] hydraulic pump (sold separately).

When not in use, pin puller components can be conveniently stored in the supplied transport and carrying case.

### Features and Benefits:

- Lightweight and portable. Powerful 40 Ton [356 kN] pulling capacity and 3.94 inch [100 mm] stroke.
- Fits in tight spaces. Consumes minimal work room.
- Removes joint pins of up to 19.88 inch [505 mm] in length when the maximum number of five column sections is installed (purchase of additional column sections required).
- Aluminium body hydraulic cylinder with hollow plunger includes built-in carrying handle, adapter plate and integral plunger return spring.
- C-shaped steel column sections lock together and form a rigid unit when assembled, allowing one operator to manipulate the tool.
- Convenient split quick nut simplifies assembly and reduces setup and removal time.
- Included Enerpac CR400 female hydraulic coupler allows quick connection of compatible Enerpac hydraulic hoses (sold separately).

## 6.0 SETUP

### 6.1 Receiving Instructions

Visually inspect all components for shipping damage. Shipping damage is not covered by warranty. If shipping damage is found, notify carrier at once. The carrier is responsible for all repair and replacement costs resulting from damage in shipment.

## 6.2 Hydraulic Connections

The pin puller's hydraulic cylinder can be powered by an appropriate cordless, electric or air powered hydraulic pump with a maximum psi setting of 10,000 bar [700 psi]. A hand operated pump can be used, but will result in slower operation than if a powered pump is used.

The pump must be equipped with either a pressure release valve or a 3-way control valve suitable for use with a single-acting hydraulic cylinder.

**NOTICE** Installation of a pressure gauge (user-supplied) in the hydraulic circuit is strongly recommended. All hoses couplers, fittings and other hydraulic components used with the PPH40 hydraulic cylinder must be rated at 10,000 psi [700 bar].

The cylinder includes a pre-installed Enerpac CR400 female high flow coupler which is compatible with various Enerpac hydraulic hoses that use the Enerpac CH604 male coupler.

When making hydraulic connections, be certain that the coupler halves are fully engaged. Verify that the collar of the female coupler is fully threaded onto the male coupler and that there are no visible threads. Check that there are no leaks after the system is under pressure.

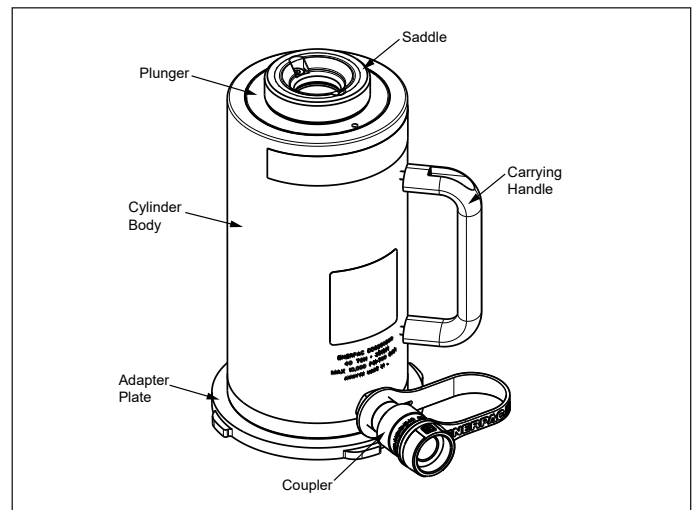

Figure 4: Hydraulic Cylinder, PPH40

### 6.3 Hydraulic Oil Requirements

Use only Enerpac HF hydraulic oil in the pump reservoir. Enerpac HF is available from Enerpac distributors and Enerpac authorized service centers.

**NOTICE** Use of other oils may result in improper operation and/or damage to the hydraulic cylinder. Such damage is not covered under the Enerpac product warranty.

### 6.4 Air Removal

When hydraulic connections are made for the first time, air will be trapped inside the cylinder, hoses and other system components. This trapped air can cause erratic operation of the cylinder plunger.

**NOTICE** The following procedure must be performed with the cylinder UNLOADED. Before beginning, refer to pump manufacturer's instructions for reservoir air venting instructions specific to your pump.

To remove air from the system:

1. Connect hydraulic hose between pump and cylinder. Be sure pump reservoir is filled with the proper amount of hydraulic oil.
2. Start the pump and run the cylinder through several complete advance-retract cycles. Do this with the cylinder plunger pointing DOWN, and with the pump positioned *higher* than the cylinder or tool. See Figure 5.
3. When the cylinder plunger advances and retracts smoothly without hesitation, it is an indication that air has been successfully vented from the system. Fully retract the cylinder.
4. Check hydraulic oil level in pump reservoir. Add additional oil if oil level has dropped.

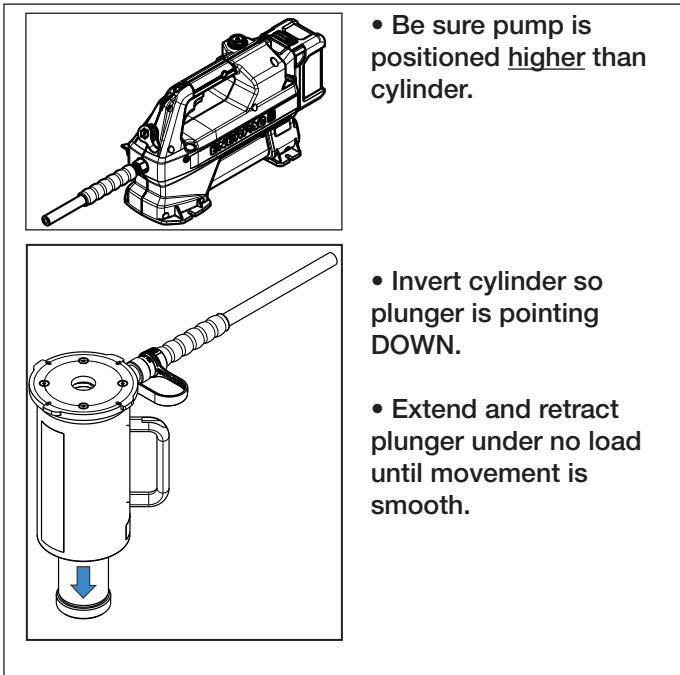

Figure 5: Air Removal

## 6.5 Threaded Rod Requirements

Threaded rod is not available for purchase from Enerpac and must be supplied by the user. All threaded rod must meet the following requirements:

- **Imperial Thread:** Use only Grade 8, Grade BD (or equivalent tensile strength) high-strength steel threaded rod. Thread size can be either 1"-14 UNS or 1-1/4"-12 UNF.
- **Metric Thread:** Use only Class 10.9 (or equivalent tensile strength) high-strength steel threaded rod. Thread size must be M30 x 3.5.

**DANGER** Failure to use threaded rod of the correct specifications will result in rod breakage when hydraulic force is applied. Death or serious personal injury will result if failure occurs and broken or loose parts become projectiles and strike persons in the work area.

The threaded rod must be in good condition, free of wear, corrosion, nicks and burrs or other imperfections. .

**IMPORTANT:** Refer to Section 6.5 for threaded rod requirements and specifications.



Figure 6: Threaded Rod (typical - user-supplied)

## 6.6 Enerpac Quick Nut Requirements

Before proceeding, be certain that you have the proper Enerpac quick nut for the threaded rod size being used:

- One quick nut, size 1-1/4"-12 UNF, is included with the PPH40 kit.
- Quick nuts in sizes 1"-14 UNS and M30 x 3.5 are available as optional accessories.

Always use the correct Enerpac quick nut for the threaded rod size being used.

The quick nut must be in good condition, free of wear, corrosion, nicks and burrs or other imperfections. Before use, verify that the quick nut closes and locks securely, and that it rotates freely on the threaded rod, and that the threads are not damaged, worn or corroded.

Refer to Section 3.3 for quick nut model numbers and detailed specifications.

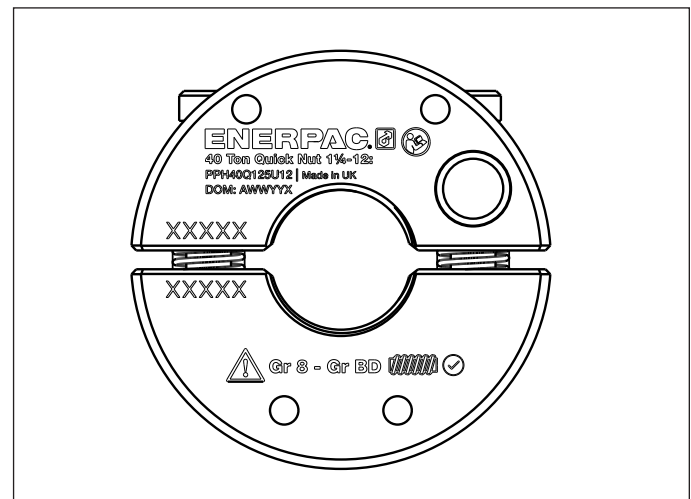

Figure 7: Quick Nut (size 1-1/4"-12 UNF shown)

## 7.0 INSTALLATION

### 7.1 Puller Orientation

In most applications, the puller is mounted horizontally, beside the pin to be pulled.

If desired, the puller can also be mounted vertically, directly above or below the pin to be pulled.

However the puller is oriented, arrangements must be made to provide adequate support (using hoist and sling or by other suitable means) so the puller does not drop or tip when the pin is fully removed.

### 7.2 Column Section Details

- Each column section is of identical shape and size. The longer the length of the pin being pulled, the more column sections will be required. Each column section corresponds to approximately 3.97 inches [101 mm] of pin length.
- The pin puller kit includes *three* column sections as standard equipment. Up to *two* additional column sections (available as optional accessories) can be installed to pull larger pins. Never install more than a total of *five* column sections.
- Each column section flange includes a spring loaded lock pin and a series of spring loaded plungers. After installation, these items keep the column sections securely attached to each other and also to the adapter plate of the hydraulic cylinder.

### 7.3 Column Section Assembly & Disassembly

- To assemble each column section: align tabs on column section with slots on the adjacent column section. Bring parts together. Then rotate the column section until it locks into place. Verify that the locking pin has engaged.
- To disassemble each column section: Rotate the column section while simultaneously pulling the locking pin on the adjacent column section. Align tabs with slots and then remove the column section.

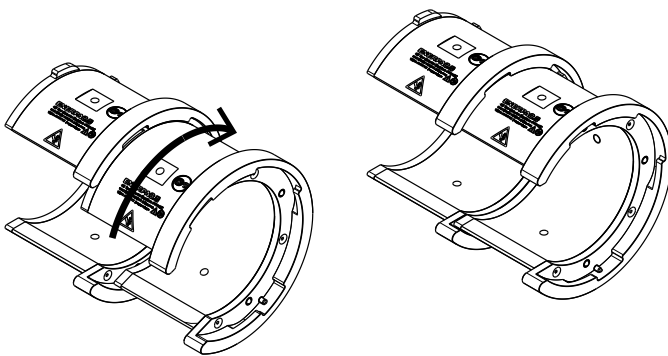

Figure 8: Column Section Assembly Details

### 7.4 Puller Assembly and Mounting

Assemble and mount the pin puller as described in the following procedure. In the following steps, it is assumed that the puller assembly will be oriented in the horizontal position and located directly to the left or right of the pin to be pulled.

1. Determine the number of column sections that will be required for the length of the pin being removed. Refer to the table in Section 3.6 for additional information.
2. Place the hydraulic cylinder and column sections on a flat work surface, such as a shop workbench or solid ground. Be sure the cylinder is disconnected from the hydraulic hose and that the plunger is fully retracted.
3. Check all components for signs of wear or damage before assembly. Repair or replace components as required before proceeding. Be sure all components are clean and free of dirt and grit.

**NOTICE** It is usually easiest to stack the column sections and cylinder vertically as parts are assembled in the following steps. The assembly can be repositioned in the horizontal orientation prior to lifting.

4. Assemble the column sections together, using the required number of sections for your application. Note that the column sections can only be assembled to each other in one position with the gaps aligned.
5. Assemble the hydraulic cylinder to the column section assembly. Note that the cylinder adapter plate allows the cylinder to be installed to the column sections in any one of four positions, 90 degrees apart. Choose whichever position will be most convenient when the assembly is mounted.
6. Set aside the cylinder and column section assembly until it is ready to be lifted into place later in this procedure.
7. On the machinery being serviced, remove flag retaining screws or protective cover (if present) securing the pin to be removed.
8. Install the threaded rod (user-supplied) fully into the tapped hole of the pin.

**NOTICE** Be sure that the threaded rod is long enough so that it will protrude at least 1 inch [25.4 mm] from the face of the installed quick nut when the cylinder and column section assembly is mounted in the following steps.

**NOTICE** Lifting arrangements will vary depending on the work environment, available equipment, user preferences and other factors. Use of a hoist and sling in the following steps is strongly recommended. The puller assembly must remain fully supported and balanced as it is lifted into position and installed. Refer to the table in Section 3.6 for weights.

9. Position the cylinder and column section assembly on its side so it is horizontally oriented.

10. Install the supplied eyebolt into the appropriate tapped hole on one of the column sections. The proper eyebolt location (to provide optimum balance) will vary depending on the number of column sections installed, and the lifting arrangement used.

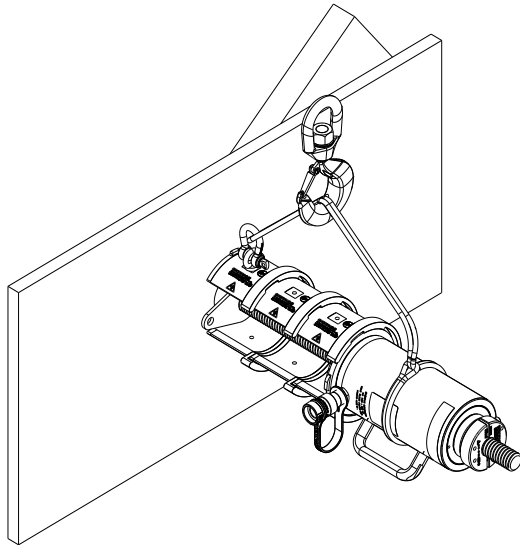

Figure 9: Pin Puller Assembly Installed & Supported (Typical)

**NOTICE** In the next step, wrap the sling securely *around* the cylinder body and route it *through* the opening of the cylinder carrying handle. DO NOT attach the sling directly to the carrying handle.

11. Connect one end of the sling to the eyebolt installed in step 10. Wrap the other end of the sling around the cylinder body to provide additional support. Make adjustments as required, so that the assembly will be balanced when lifted into position.
12. Slowly raise the assembly with the hoist, ensuring that it remains balanced. Position the opening in the leading column section around the threaded rod. Then carefully guide the entire assembly over the rod until the rod end slides fully through the hollow center of the hydraulic cylinder.
  - If the pin being removed contains a welded-on cover or “flag”, the opening in the assembled column sections must be located in the same position as the flag.
  - If the pin contains no flag, the opening in the column sections should be oriented sideways to help prevent the threaded rod and pin from dropping out during removal procedures.
13. Position the faceplate of the leading column section firmly against the structure surrounding the pin to be removed.

**NOTICE** Before continuing:

- Be sure that the surface surrounding the pin is clean and flat, with minimal irregularities and that it is not slanted or sloped.
- Verify that the faceplate of the leading column section is perpendicular to the axis of the pin, and that it is in full contact with the surface surrounding the pin (no gaps).

- Check that the column sections are parallel with and centered around the threaded rod and pin.

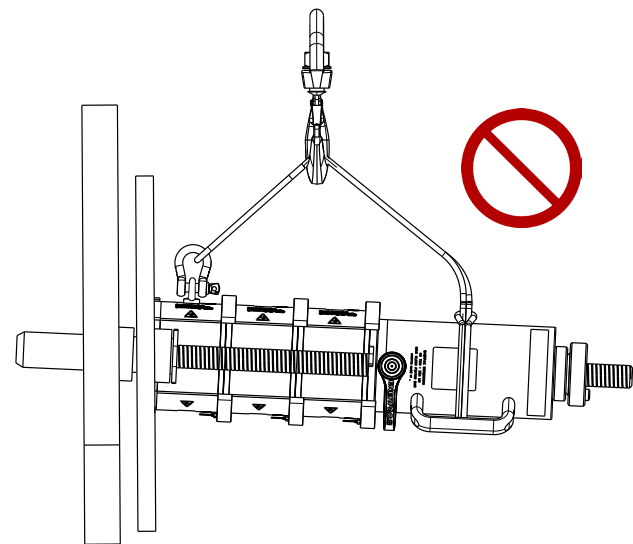
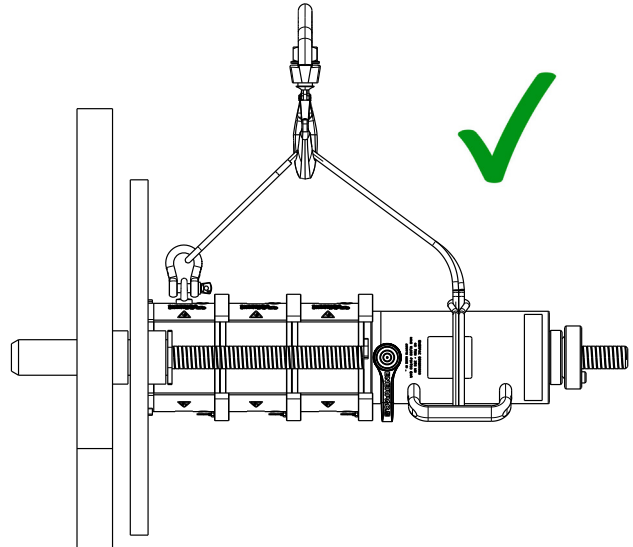

Figure 10: Checking for Proper Positioning

14. Press the release button on the quick nut to open it. With the conical side facing towards the cylinder saddle, slide the quick nut along the threaded rod toward the cylinder, until it is about 1/4 inch [6 mm] from the cylinder saddle.
15. Squeeze the quick nut halves together until the locking mechanism engages. Then, by hand, rotate the quick nut clockwise on the threaded rod until its conical surface is tight against the saddle surface. Verify that the threaded rod protrudes at least 1 inch [25 mm] from the face of the quick nut.
16. At this time, check that the leading column section remains firmly and evenly positioned against the surface surrounding the pin to be removed.
17. Verify that there are no obvious alignment problems or loose parts.

## 8.0 OPERATION

### 8.1 Operating Precautions

**⚠ WARNING** Death or serious personal injury could occur if the following instructions and precautions are not followed:

- Before operation, ensure that all personnel read and understand the safety information and instructions contained in this manual. Refer to Section 1.1.2 of this manual for additional pin puller safety instructions and precautions.
- Always wear appropriate personal protective equipment (P.P.E.) such as safety glasses, steel toe boots, face shield, etc. while using the pin puller.
- Never begin a pin pulling procedure unless the assembled cylinder and column sections are evenly supported by a hoist and sling (or other suitable lifting device) of adequate rated capacity.
- Be certain that the puller assembly remains evenly supported by the hoist and sling during the pin pulling procedure. If unsupported, the entire pin puller assembly will drop immediately when the pin is fully removed, or if threaded rod breakage occurs during pulling.
- Stay clear of area around and below the pin puller during use. Threaded rod and pin may drop and swing when pin is removed. Refer to additional safety instructions and Figure 1 graphic in Section 1.1.3.
- Stay clear of the *line of fire* area when using the pin puller. If threaded rod breaks or if quick nut fails, persons in the path of the *line of fire* will be struck by dangerous projectiles. Refer to additional safety instructions in Section 1.1.3. Also see Figure 1.
- Use extreme caution to avoid pinch points. Never apply hydraulic force unless hands and fingers are clear of the pinch point areas. Never reach into or be unnecessarily close to the pin puller assembly while hydraulic force is being applied.
- Check for oil leakage as pressure begins building in the cylinder. If leaks occur, stop using the pin puller, fully relieve hydraulic pressure and repair any leaks before proceeding with use.
- Do not exceed hydraulic working pressures over 10,000 psi [700 bar] when operating the pin puller.
- Do not leave the pin puller assembly unattended while the hydraulic cylinder is under pressure.

### 8.2 Pin Removal Procedure

1. Assemble and mount the puller components as described in Section 7.4. Be sure to read and understand the safety precautions and instructions contained in Section 8.1.
2. Start the pump and build partial hydraulic pressure. Verify that the cylinder plunger begins advancing, and that the threaded rod starts moving and pulling the pin. Check that the puller remains aligned with

the pin (perpendicular with the mating surface of the machinery) and is not cocked or angled.

3. If no problems are observed, continue advancing at a higher pressure until the plunger reaches the end of its stroke or the pin is fully removed.

**NOTICE** If the pin was fully removed in step 3, skip steps 4 through 7 and go to step 8.

4. Stop the pump and relieve hydraulic pressure. Allow cylinder plunger to fully retract.

**NOTICE** The cylinder plunger stroke is 3.94 inches [100 mm]. For this reason, longer pins will require several pull cycles to fully complete their removal.

5. Press the release button on the quick nut to open it. With the conical side facing towards the cylinder saddle, slide the quick nut along the threaded rod toward the cylinder, until it is about 1/4 inch [6 mm] from the saddle.
6. Squeeze the quick nut halves together until the locking mechanism engages. Then, by hand, rotate the quick nut clockwise on the threaded rod until its conical surface is tight against the saddle surface. Verify that the threaded rod protrudes at least 1 inch [25 mm] from the face of the quick nut.
7. Repeat steps 2 through 6 as needed, performing additional pull cycles until the pin is fully removed.
8. When the pin has been fully removed, stop the pump and fully relieve hydraulic pressure. Allow the cylinder plunger to fully retract.

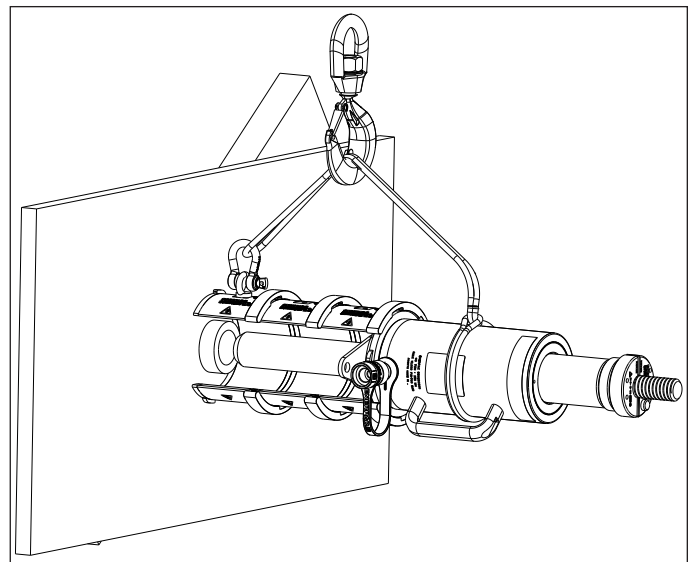

Figure 11: Pin Pulling Process (Typical)

## 8.3 Disassembly

1. Be sure that the hydraulic pump is OFF and that pressure is zero (0) psi/bar. Verify that the cylinder plunger is fully retracted.
2. Check the hydraulic hose for stiffness or other signs of trapped pressure. If no pressure is found, disconnect the hydraulic hose from the cylinder.
3. Lower the cylinder and column section assembly using the hoist and sling. Place it on a suitable flat work surface to allow further disassembly.
4. Press the release button on the quick nut and remove the quick nut from the threaded rod. Remove the threaded rod and pin from the pin puller assembly.
5. Unscrew and remove the threaded rod from the pin.
6. Place the pin puller in a vertical orientation. Disassemble each column section by pulling the retaining pin outward while simultaneously rotating the column section.
7. Wipe off any oil or grease from the puller components. Reinstall the dust cap on the cylinder coupler.
8. Store the components in the protective storage case provided with the puller.

## 9.0 CLEANING AND MAINTENANCE

### 9.1 Hydraulic Cylinder Inspection

- Wipe off any loose dirt or dust from the cylinder body.
- Check the cylinder saddle for nicks, corrosion deformation or other problems. Replace if damaged or worn. Refer to Section 9.2 for procedure.
- Check the cylinder for obvious signs of damage. Verify that there are no oil leaks. Also check that the cylinder plunger returns to the fully retracted position when pressure is relieved.
- Verify that the cylinder hydraulic coupler is in good condition and that the dust cap remains attached.

**⚠ WARNING** Only experienced and qualified technicians should be permitted to open and repair the hydraulic cylinder. Cylinder contains an internal plunger return spring under tension. When cylinder is disassembled, the spring and related components may become dangerous projectiles. Serious personal injury could result if these parts strike persons in the work area.

### 9.2 Hydraulic Cylinder Saddle Replacement

Replace the hydraulic cylinder saddle as described in the following steps. See Figure 12. Also refer to Figure 16 for part numbers.

1. Be sure that the hydraulic pump is OFF and that pressure is zero (0) psi/bar. Verify that the cylinder plunger is fully retracted.

2. Check the hydraulic hose for stiffness or other signs of trapped pressure. If no pressure is found, disconnect the hydraulic hose from the hydraulic cylinder.
3. Place the cylinder on a suitable flat work surface.

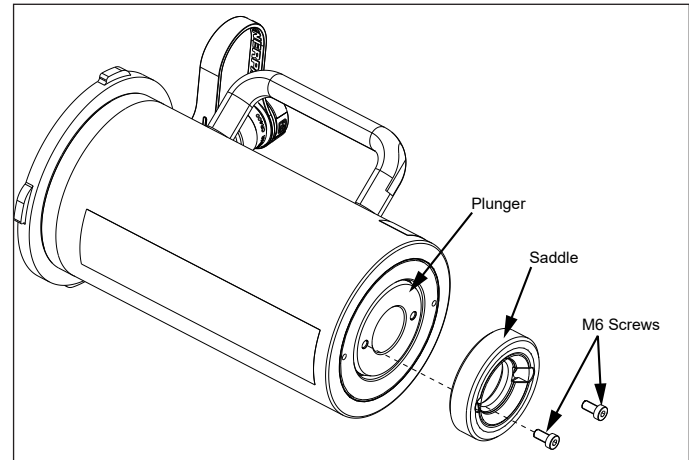

Figure 12: Saddle Replacement

**NOTICE** Do not allow the plunger to rotate during adaptor installation. Plunger rotation may damage the internal seals and/or the plunger return spring.

4. Remove two M6 screws securing the saddle to the plunger. Remove screws and saddle.
5. Be sure the plunger surface is clean and free of any corrosion, oil, dirt or nicks and scratches.
6. Place the new saddle on the plunger surface. Align bolt holes.
7. Apply Loctite 242 thread locking compound to threads of new M6 screws included with the replacement saddle. Refer to manufacturer's product data sheet for Loctite application information.
8. Secure the replacement saddle with the two new M6 screws. Torque screws to 60 in-lbs [6.5 Nm].

### 9.3 Hydraulic Cylinder Adapter Plate Replacement

Replace the hydraulic cylinder adapter plate as described in the following steps. See Figure 13. Also refer to Figure 16 for part numbers.

1. Be sure that the hydraulic pump is OFF and that pressure is zero (0) psi/bar. Verify that the cylinder plunger is fully retracted.
2. Check the hydraulic hose for stiffness or other signs of trapped pressure. If no pressure is found, disconnect the hydraulic hose from the hydraulic cylinder.
3. Place the cylinder on a suitable flat work surface.
4. Remove four M6 screws securing the adapter plate to the cylinder base. Remove adapter plate.
5. Be sure the cylinder base surface is clean and free of any corrosion, oil, dirt or nicks and scratches.
6. Place the new adapter plate against the cylinder base surface. Align bolt holes.



7. Apply Loctite 242 thread locking compound to threads of new M6 screws included with the replacement adapter plate. Refer to manufacturer's product data sheet for Loctite application information.
8. Secure the replacement adapter plate with the four new M6 screws. Torque screws to 60 in-lbs [6.5 Nm].

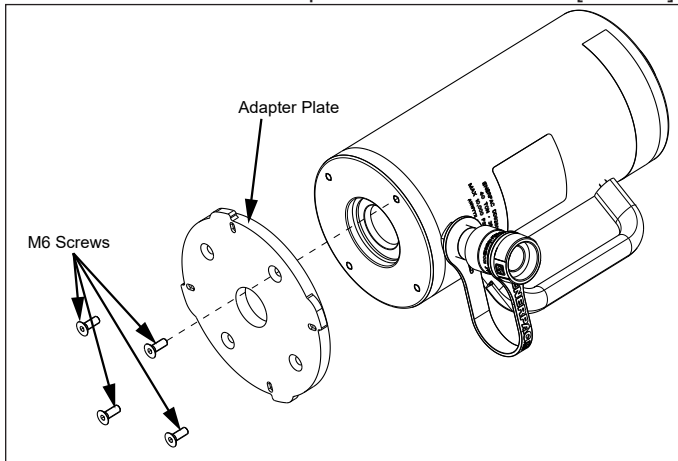

Figure 13: Adapter Plate Replacement

## 9.4 Column Section Inspection

Inspect each column section for loose or missing fasteners, missing components, corroded or deformed components. Tighten or replace components or column sections as required.

Refer to Figure 18 later in this manual for part numbers, torque values and related service information.

## 9.5 Threaded Rod Inspection

Inspect the threaded rod (user supplied) before each use. Verify that it is in good condition, free of wear, corrosion, nicks and burrs, bends or other imperfections.

Always replace threaded rod that is damaged, bent, worn or corroded.

## 9.6 Quick Nut Inspection

Inspect quick nut for loose, missing, corroded or damaged components. Tighten or replace components as required. Inspect the quick nut threads before each use. Verify they are in good condition, free of wear, corrosion, nick and burrs, or other damage. Always replace a quick nut with threads that are damaged, worn or corroded.

Refer to Figure 19 later in this manual for part numbers, torque values and related service information.

## 10.0 STORAGE

- Be sure that the hydraulic cylinder is fully retracted and that there is no remaining residual pressure.
- Disconnect hydraulic hose from cylinder coupler.
- Wipe off any loose dirt or dust from the puller components.
- Store all components in their proper pockets inside the protective storage case. Be sure the lid is closed and latched.
- Store the protective storage case and components in a secured environment, that is clean, dry and removed from direct sunlight.

## 11.0 RELIEVING TRAPPED PRESSURE IN CYLINDER

Pressure can sometimes become trapped inside a hydraulic cylinder if a hose is disconnected before pressure is completely relieved.

If a trapped pressure condition occurs, always use the Enerpac model CT604 coupler bleed tool (available from your Enerpac authorized distributor) to safely relieve the remaining pressure.

**⚠ DANGER** Never attempt to relieve hydraulic pressure by loosening a coupler. Trapped hydraulic pressure can cause a loosened coupler to dislodge unexpectedly with great force. Serious personal injury or death will result if the coupler becomes a projectile and strikes persons working in the area.

**⚠ WARNING** Loosening a coupler may result in an escape of high pressure oil that can penetrate the skin. Serious personal injury or death could result.

**⚠ WARNING** Never use a hammer and punch (or other similar method) to unseat a coupler check ball that is under pressure. Serious personal injury or death could result due to the sudden and uncontrolled escape of high pressure oil.

## 12.0 SAFE DISPOSAL PROCEDURE

- Be sure that the hydraulic cylinder is fully retracted and that there is no remaining residual pressure.
- Disconnect hydraulic hose from cylinder coupler.
- Take the hydraulic cylinder and the other pin puller components to an approved industrial recycling facility for disposal.

## 13.0 TROUBLESHOOTING

Only qualified technicians should service the pin puller. For repair service, contact your Enerpac authorized service center.

The troubleshooting guide on the following pages is intended to be used only as an aid in determining if a problem exists. A system failure may or may not be the result of a puller component malfunction. To determine the cause of the problem, the complete system must be included in any diagnostic procedure.

**⚠ WARNING** Failure to observe and comply with the following precautions could result in death or serious personal injury. Property damage could also occur.

- Never tighten or loosen hydraulic fittings while the pin puller cylinder is pressurized. Escaping oil under pressure can penetrate the skin, causing serious personal injury.
- Keep hands, fingers and other body parts clear of pinch points and moving parts when observing operation during troubleshooting. Be aware of possible pinch points noted by symbols on puller components.
- To prevent accidental operation of pin puller during servicing, always fully relieve hydraulic pressure and disconnect hydraulic hose from cylinder before performing any repair procedures.
- The hydraulic cylinder used with the pin puller contains a return spring under tension. Special disassembly techniques are required to prevent personal injury. Repairs should be performed only by a trained and qualified technician familiar with this type of cylinder.

Troubleshooting Guide - Section 1, Hydraulic Cylinder		
1. Cylinder plunger will not advance.	a. Pump release valve open.	Close pump release valve.
	b. Coupler not fully tightened.	Tighten coupler.
	c. Low oil level.	Add additional oil to pump reservoir (follow pump manufacturer's directions).
	d. Pump malfunction.	Troubleshoot pump. Make repairs and adjustments as required.
2. Cylinder plunger advances part way.	a. Low oil level.	Add additional oil to pump reservoir (follow pump manufacturer's directions).
	b. Coupler not fully tightened.	Tighten coupler.
	c. Cylinder plunger binding.	Repair or replace cylinder.
3. Cylinder plunger advances in spurts.	a. Air in hydraulic system.	Remove air from hydraulic system. See Paragraph 6.4.
	b. Cylinder plunger binding.	Repair or replace cylinder.
4. Cylinder plunger advances slower than normal.	a. Leaking connection.	Repair leaking connection.
	b. Coupler not fully tightened.	Tighten coupler.
	c. Pump malfunction.	Troubleshoot pump. Make repairs and adjustments as required.

(continued on next page)

**Troubleshooting Guide - Section 1, Hydraulic Cylinder (continued)**

<b>Problem</b>	<b>Possible Cause</b>	<b>Action</b>
5. Cylinder plunger advances but will not hold.	a. Worn or damaged seals.	Replace cylinder seals.
	b. Pump malfunction.	Troubleshoot pump. Make repairs and adjustments as required.
	c. Leaking connection.	Repair leaking connection.
	d. Incorrect system set-up.	Verify that pump is equipped with a release valve or directional control valve that can hold hydraulic pressure.
6. Cylinder leaks oil.	a. Loose connection.	Tighten connection.
	b. Worn or damaged seals.	Replace cylinder seals.
	c. Internal cylinder damage.	Repair or replace cylinder.
7. Cylinder plunger will not retract or retracts slower than normal.	a. Release valve closed.	Open the release valve.
	b. Coupler not fully tightened.	Tighten coupler.
	c. Pump reservoir over-filled.	Remove excess oil from pump reservoir.
	d. Narrow hose restricting flow.	Use wider diameter hose.
	e. Broken or weak retraction spring.	Replace cylinder retraction spring.
	f. Internal cylinder damage.	Repair or replace cylinder.
8. Oil leaking from external relief valve (if present in system).	a. Coupler not fully tightened.	Tighten coupler.
	b. Restriction in return line.	Remove restriction.

**Troubleshooting Guide, Section 2 - Pin Puller**

<b>Problem</b>	<b>Possible Cause</b>	<b>Action</b>
1. Threaded rod breaks while pulling pin.	a. Pin retainer flag preventing movement of pin.	Remove bolts securing pin retainer flag before beginning the pulling procedure.
	b. Threaded rod does not meet required minimum strength specifications.	Use threaded rod of the proper specifications. Refer to Section 6.5 for additional information.
	c. Threaded rod incorrect size.	Use proper size threaded rod. Refer to Section 6.5 for additional information.
	d. Threaded rod worn, corroded or damaged.	Replace with new threaded rod of the proper specifications and size.
2. Damage to faceplate and/or mounting screws on leading column section.	Uneven surface around pin.	Surface around pin being removed should be reasonably flat and free of dirt or corrosion.
	Puller positioned at an angle.	Loosen quick nut and realign puller. Be sure threaded rod is straight with no bends.  Puller components should be in alignment with axis of pin and perpendicular to the machinery surface surrounding the pin.
3. Puller assembly drops suddenly after pin is fully removed.	Cylinder and column section assembly not supported.	The assembly must be evenly supported by a hoist and sling (or other suitable lifting device) prior to applying hydraulic force.  Assembly will drop immediately if it is not supported when pin is removed.
4. Column sections will not lock together or are loose when assembled.	a. Locking pin worn or sticking.	Clean or Replace parts as required.
	b. Spring loaded plunger pins worn or sticking.	Clean or Replace parts as required.
	c. Column Section faceplate damaged.	Replace faceplate.

# 14.0 REPAIR PARTS SECTION

CONTENTS	PAGE
FIGURE 15: MAIN ASSEMBLY .....	23
FIGURE 16: HYDRAULIC CYLINDER, EXTERIOR VIEWS.....	24
FIGURE 17: HYDRAULIC CYLINDER, SECTIONAL VIEW.....	26
FIGURE 18: COLUMN SECTION.....	28
FIGURE 19: QUICK NUT ASSEMBLIES.....	29

**Figure 15: Main Assembly**

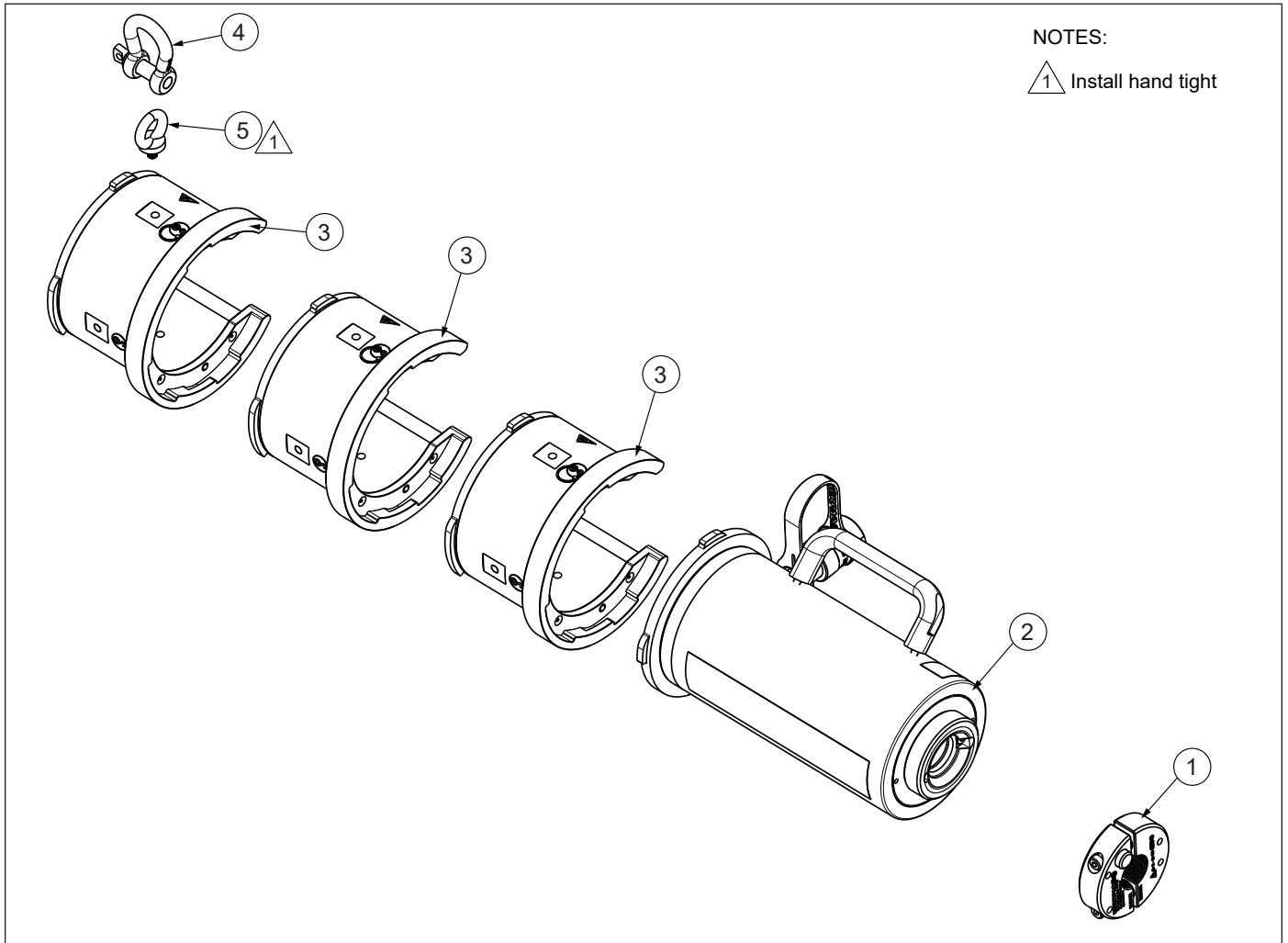

**Parts List for Figure 15**

Item	Description	Qty	Part Number
1	Assembly, Quick Nut	1	(See Figure 19)
2	Cylinder, Aluminium, PPH40	1	(See Figure 16 and Figure 17)
3	Column Section	3	(See Figure 18)
4	Shackle, 7/16" 1.5 Ton	1	DD9607056SR
5	Eyebolt, M8 x 1.25	1	DD9606667SR

**Figure 16: Hydraulic Cylinder, Exterior Views**

NOTES:

- △3 Torque to 60 in-lbs [6.5 Nm].
- △4 Secure with Loctite 242 thread locking compound.
- Refer to manufacturer's technical data sheet for application instructions.
- △5 Cylinder model number and specifications.
- △6 Position decal 180 degrees from coupler.

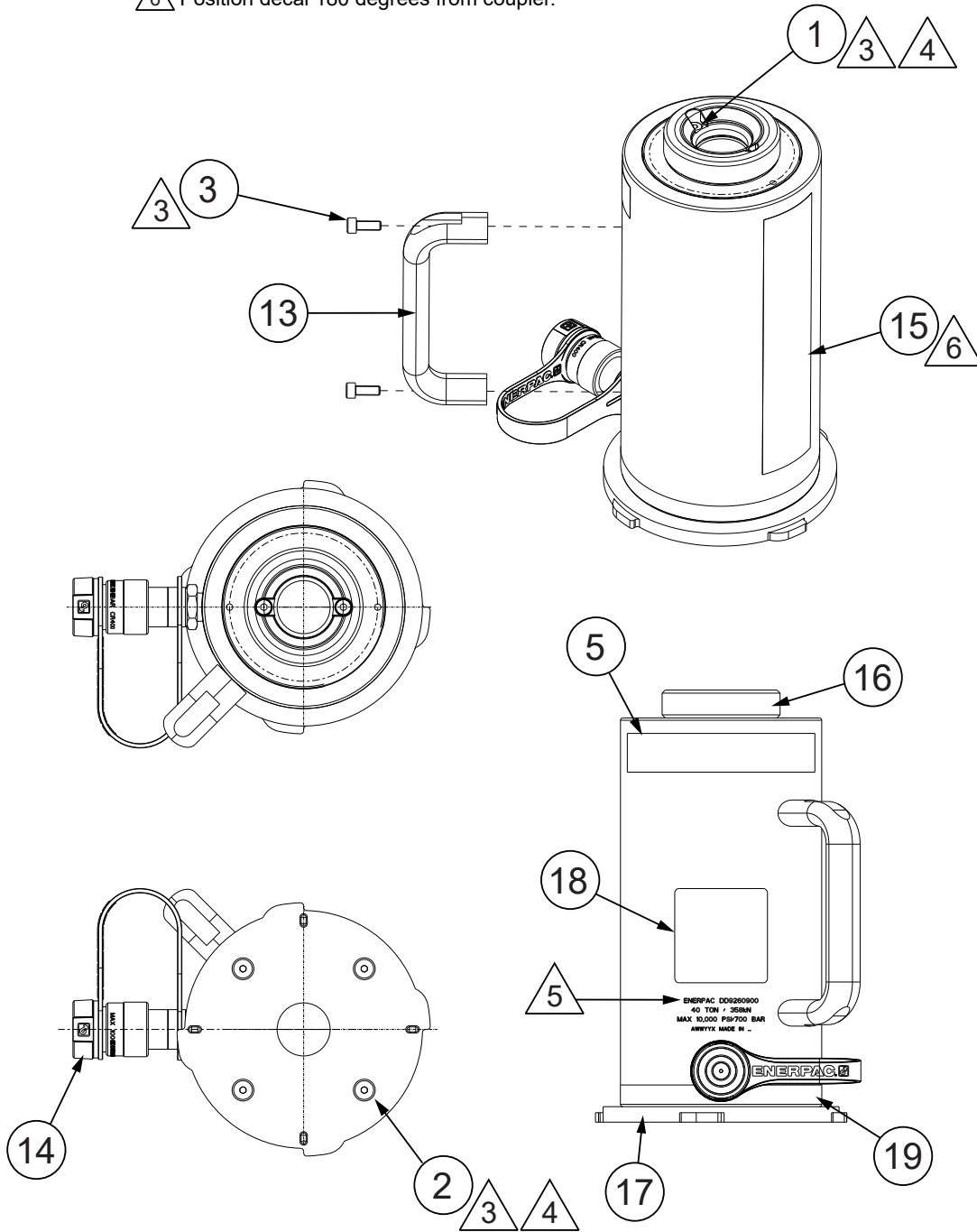



## Parts List for Figure 16

Item		Description	Qty	Part Number
1	✦	Screw, LHCS, Hex, M6 x 1 x 12, 10.9, Plain	2	CBA617028-1D
2	❖	Screw, FHS, Hex, M6 x 1 x 20, 10.9, Plain	4	CBA621028-1B
3		Screw, SHCS, Hex, M6 x 16.00, Stl/8.8, Zinc	2	CBE619028-1A
5	⊙	Warning Label, Do Not Disassemble	1	DA6027026
13		Handle	1	DC5477070
14	⊙	Dust Cap	1	DD1782020
15		Decal, Enerpac Aluminium	1	DD8835026
16	✦	Saddle, Quick Nut, RACH30	1	DD9166045
17	❖	Plate, Cylinder Adapter 127mm ID, PPH40	1	DD9169101
18		Decal, UIN, PPH40 Cylinder	1	DD9332026
19		Decal, Yellow Band, PPH40 Cylinder	1	DD9584026
⊙ Items included in Cylinder Repair Parts Kit, RACH30K50.				
✦ Items included in Replacement Saddle Kit, DD9166045SR.				
❖ Item included in Cylinder Plate Adapter Kit, DD9169101SR.				

# Figure 17: Hydraulic Cylinder, Sectional View

NOTES:

△1 Torque to 75 ft-lbs [102 Nm].

△3 Torque to 20 ft-lbs [27 Nm].

**⚠ WARNING** Cylinder contains an internal plunger return spring under tension. When cylinder stop ring (item 20) is removed, stop ring and spring (item 24) will release and may become dangerous projectiles. Serious personal injury could result if these parts strike persons in the work area.

Only experienced and qualified technicians should be permitted to open and repair the cylinder.

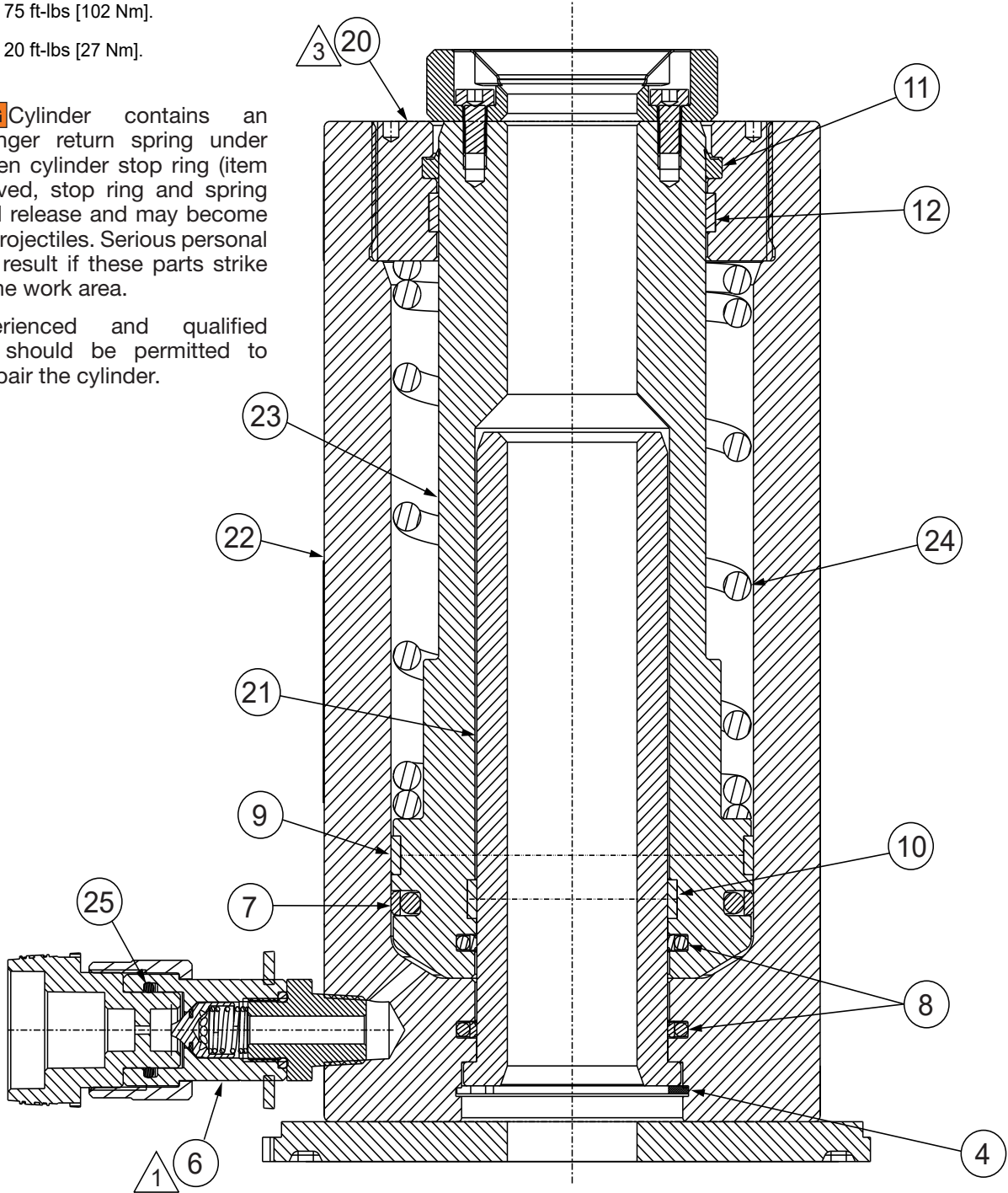

## Parts List for Figure 17

Item		Description	Qty	Part Number
4	⊙	Retaining Ring	1	CCA1058044-1C
6		Female Coupler	1	DC1389900
7	⊙	Piston Seal	1	DC5403076
8	⊙	Seal, Center Guide	2	DC5404076
9	⊙	Wear Ring, Piston	1	DC5414155
10	⊙	Wear Ring	1	DC5415155
11	⊙	Rod Wiper, RACH 30	1	DC5427776
12	⊙	Wear Ring, Piston	1	DC5436155
20		Stop Ring, RACH30	1	RACH30044
21		Center Tube	1	RACH304005
22		Cylinder Base	1	RACH304030
23		Plunger	1	RACH304040
24		Spring	1	RACH304110
25	⊙	O-Ring, Coupler	1	B1116803
⊙ Items included in Cylinder Repair Parts Kit, RACH30K50.				

**Figure 18: Column Section**

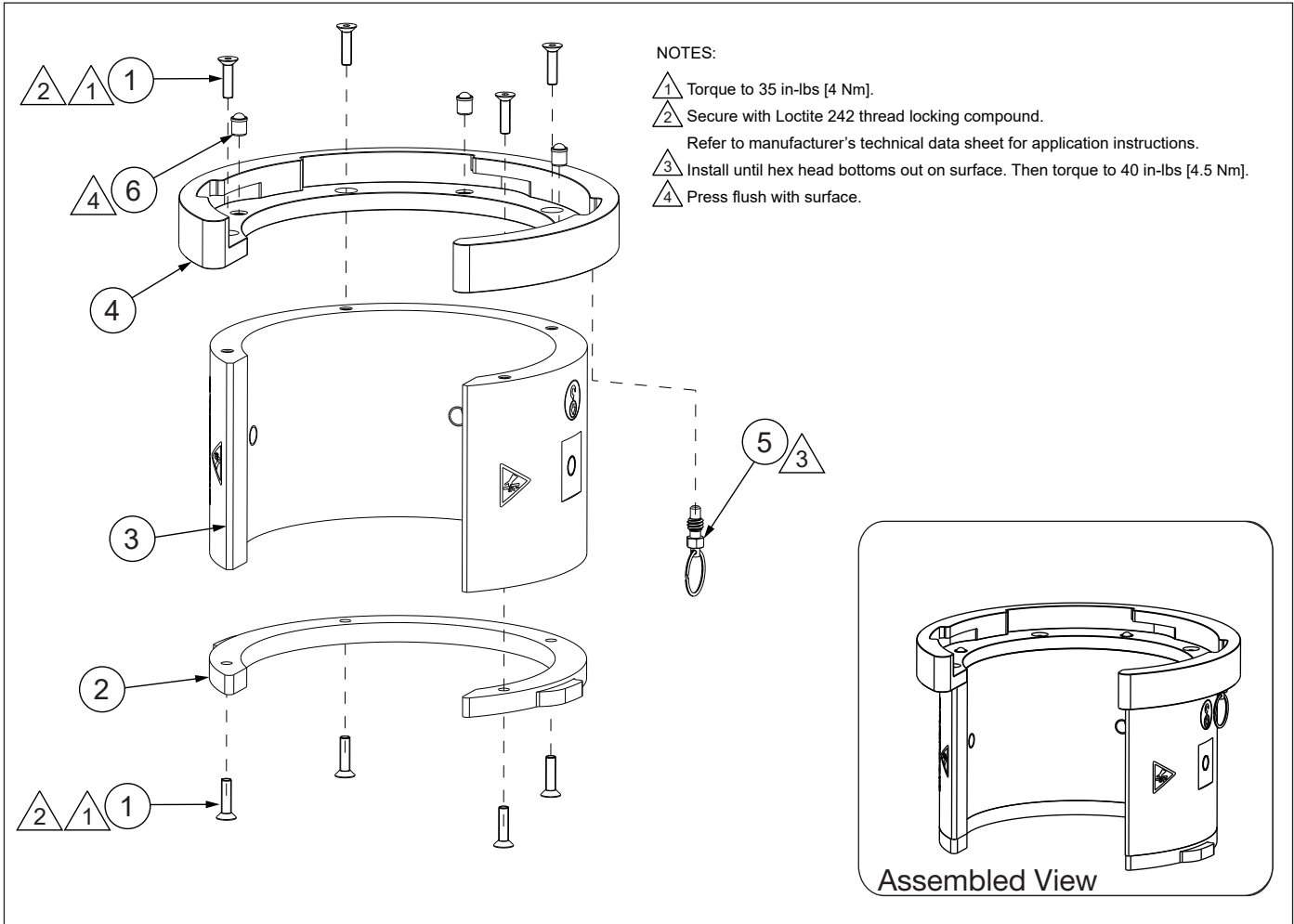

**Parts List for Figure 18**

Item		Description	Qty	Part Number
1	■◆	Screw, FHS, Hex M4 x 0.7 x 16, 10.9, Plain	8	CBA419028-1B
2	■◆	Keeper Plate, Column Lock (faceplate)	1	DD9171101
3	■	Column, Body 127 mm x 86 mm Tall	1	DD9178301
4	■	Locking Flange	1	DD9489101
5	■	Pin, Lock, Spring-loaded	1	DD9577061SR
6	■	Plunger, Spring	3	DD9589040

■ Items included in 40 Ton Locking Column Accessory, PPH40C.

◆ Items included in Faceplate Kit, DD9171101SR. Kit includes 4 screws.

NOTE: Items available only in kits (not sold separately).

# Figure 19: Quick Nut Assemblies

NOTES:

- 1 Secure with Loctite 242 thread locking compound.  
Refer to manufacturer's technical data sheet for applications instructions.
- 2 Torque to 22 ft-lbs [30 Nm].

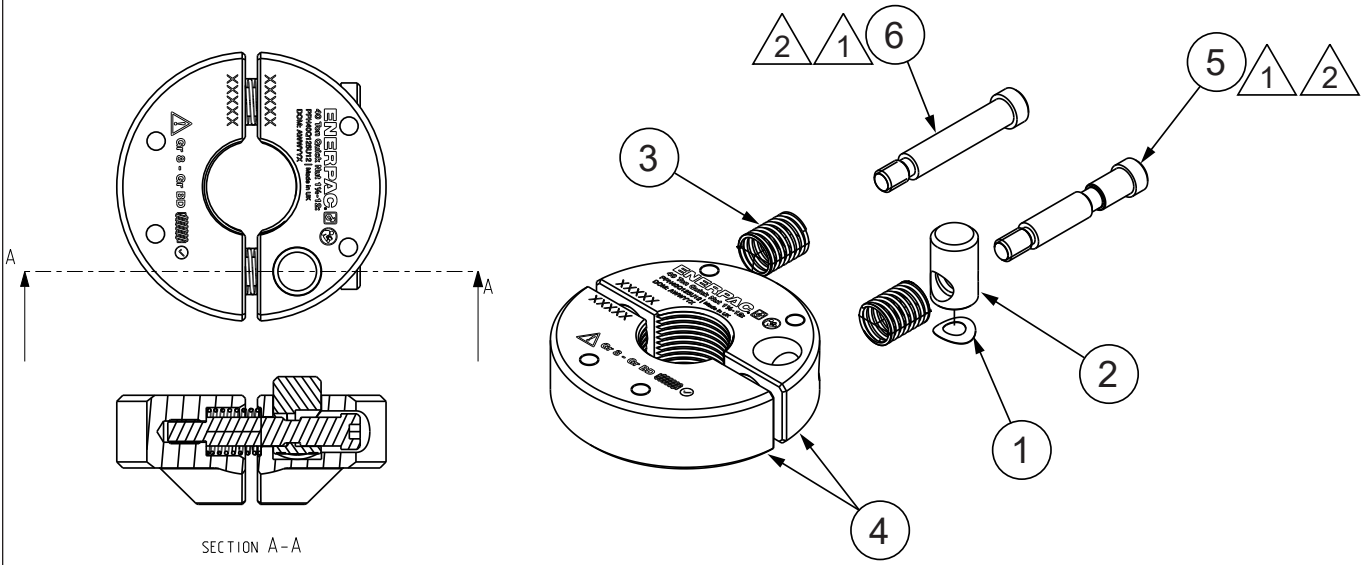

SECTION A-A

Quick Nut Body Markings - Item 4

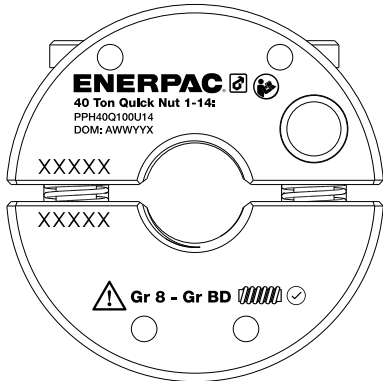

PPH40Q100U14

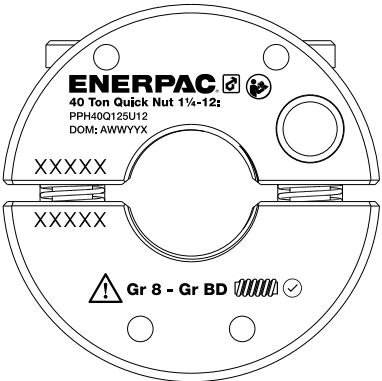

PPH40Q125U12

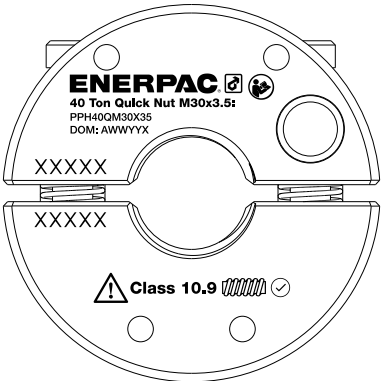

PPH40QM30X35

## Parts Lists for Figure 19

- Quick Nut Model Number PPH40Q100U14 - Thread Size 1"-14 UNS
- Quick Nut Model Number PPH40Q125U12 - Thread Size 1-1/4"-12 UNF
- Quick Nut Model Number PPH40QM30X35 - Thread Size M30 x 3.5

Item	Description	Qty	Part Number		
			PPH40Q100U14	PPH40Q125U12	PPH40QM30X35
1	◆ Spring, Curved Washer	1	001HN0026403		
2	◆ Lock Release Button	1	004BK0001755		
3	◆ Spring, Compression	2	016AA0025763		
4	Body, Quick Nut	1	DD9496190	<b>DD9575190</b>	DD9576190
5	◆ Lock Pin, 40T, Quick Nut	1	DD9510128		
6	◆ Guide Pin, 40T, Quick Nut	1	DD9512128		
◆ Items included in 40 Ton Quick Nut Service Kit, PPH40QK. NOTE: Items available only in kit (not sold separately).					

**NOTES**

Horizontal lines for writing notes.

