



DewPro[®] MMY30

Dew point transmitter

The DewPro MMY30 is a loop-powered transmitter with 4 to 20 mA output. The DewPro MMY30 is specifically designed to measure dew point or ppm in gases at line pressure or atmospheric pressure. The planar aluminum oxide sensor provides excellent corrosion resistance, longer calibration stability, quick response times, and an exceptionally low temperature coefficient. The optional integrated display with user interface provides full programming and diagnostic capability.

The DewPro MMY30 features an integral flow cell for filtration and flow regulation making it ideal for monitoring the moisture content in various process environments. Several options are available for the process connection allowing easy installation of the transmitter. Applications include desiccant air dryers, pipeline natural gas and industrial gases.

Features

- Loop-powered, 4 to 20 mA transmitter
- Fast response planar aluminum oxide sensor
- Integral filtering and flow regulation
- Trouble-free indoor or outdoor mounting
- Field validation with the MMY245 moisture analyzer
- Microcontroller electronics in Type 4X/IP67 enclosure

Options

- Integrated display with user interface
- FM approved intrinsically safe/explosion-proof, Class I,II,III, Division 1 and 2, Groups A,B,C,D,E,F&G hazardous (classified) locations
- English or metric fittings
- External display available with loop-powered supply and alarm contacts

DewPro MMY30 specifications

Sensing element

Planar aluminum oxide sensor

Measurement range

-130°F to 50°F (-90°C to 10°C) dew point temperature; 0 to 10, 0 to 100, 0 to 1000 ppmv (fully adjustable with integral display)

Recommended recalibration cycle

12 months, depending on the application

Calibration accuracy

±3.6°F (±2°C) dew point at 77°F (25°C)

Maximum sensor relative humidity

50% at dew point temperature > 32°F (0°C)

Operating and storage temperature range

Process: -40°F to 122°F (-40°C to 50°C)

Electronics: -40°F to 185°F (-40°C to 85°C)

Air bleed off at 100 psig (7 bar)

Approximately 1 SCFH (28 sl/h)

Maximum operating pressure

450 psig (31 bar, 3.1 MPa)

Inlet filter: 2 micron sintered stainless steel

Helium leak-rate

<10⁻⁶ mbar l/s

Output

4 to 20 mA loop-powered, 16 :A resolution

Flow block

316 stainless steel with 1/2 in MNPT or G 1/2 thread (DIN ISO 228)

Wrench width for flow block

1-5/8 in (42 mm)

Electronics

Microcontroller operated

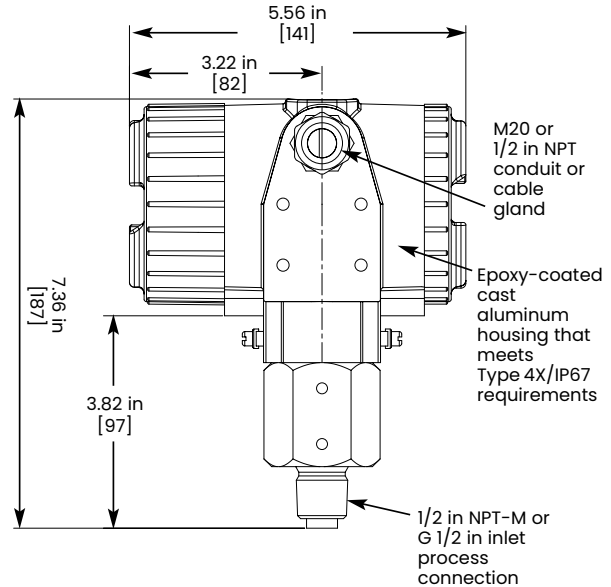

DewPro MMY30 with display option

Optional display

Four-digit numeric display with bar graph and matrix position indication. Four user interface keys for unit selections, output adjustments and ranging.

Power supply

24 VDC nominal, 12 to 30 VDC range

Protection

Type 4X/IP67

Weight

4.4 lb (2 kg)

European compliance

Complies with EMC Directive 89/336/EEC and PED 97/23/EC for DN<25

Optional certifications/approvals

- FM IS Class I,II,III, Division 1, Groups A,B,C,D,E,F&G, T5
- FM XP-IS Class I, Division 1, Groups A,B,C&D, T5
- FM NI Class I, Division 2, Groups A,B,C&D, T4A DIP Class II,III, Division 1, Groups E,F&G, T5
- ATEX and IECEx
Ex db IIC T6 Gb
Ex tb IIIC T85°C Db
IP66

Panametrics, a Baker Hughes Business, provides solutions in the toughest applications and environments for moisture, oxygen, liquid and gas flow measurement. Experts in flare management, Panametrics technology also reduces flare emissions and optimizes performance.

With a reach that extends across the globe, Panametrics' critical measurement solutions and flare emissions management are enabling customers to drive efficiency and achieve carbon reduction targets across critical industries including: Oil & Gas; Energy; Healthcare; Water and Wastewater; Chemical Processing; Food & Beverage and many others.

Join the conversation and follow us on LinkedIn
[linkedin.com/company/panametricscompany](https://www.linkedin.com/company/panametricscompany)